

ROBOTICS DESIGN SYSTEM

GUIDE FOR BUILDING THE

PROTOBOT AND TUMBLER

NOTE: This kit requires other components which are not included in order to build a complete working robot. The primary additional required component is a compatible VEX EDR robot control system.



5 HOLE

10 HOLE

15 HO

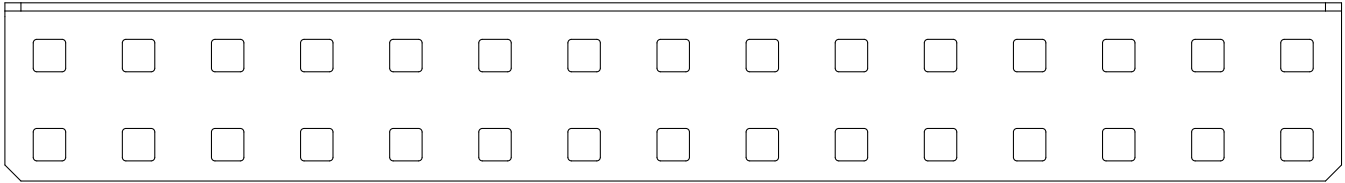

[A15] CHASSIS BUMPER, 15 HOLE

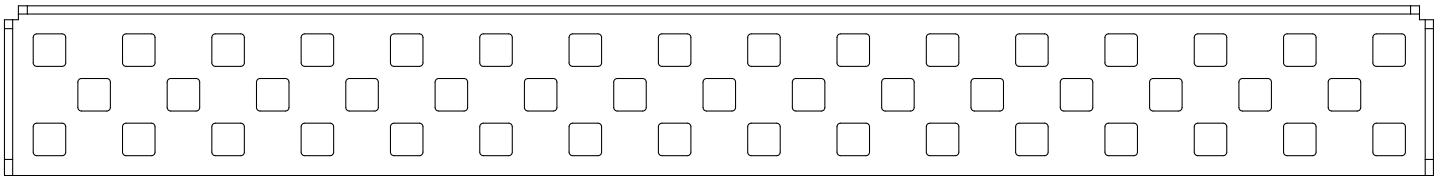

[R15] CHASSIS RAIL, 16 HOLE

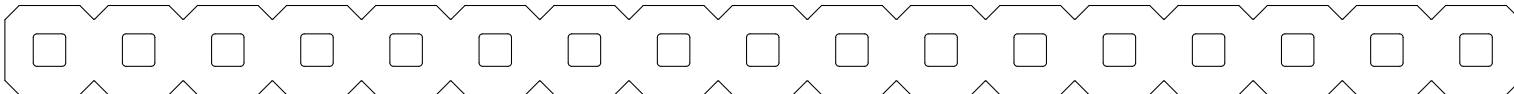

[B25] BAR, 25 HOLE

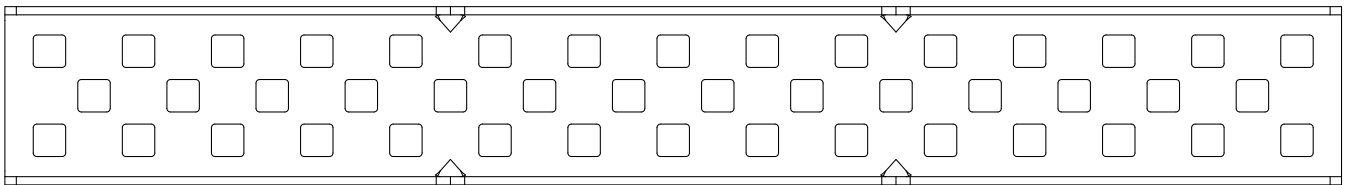

[C15] C-CHANNEL, 15 HOLE

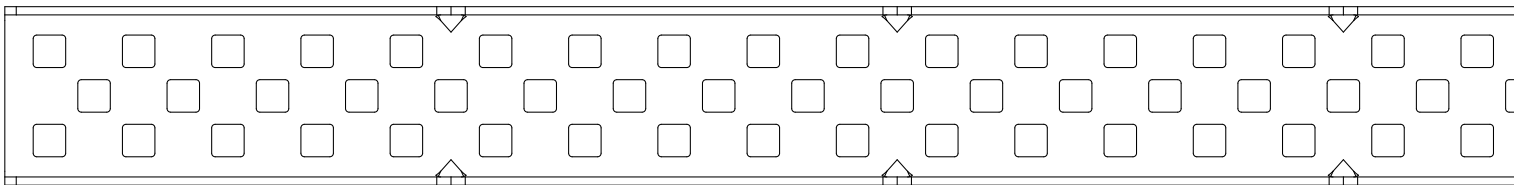

[C25] C-CHANNEL, 25 HOLE

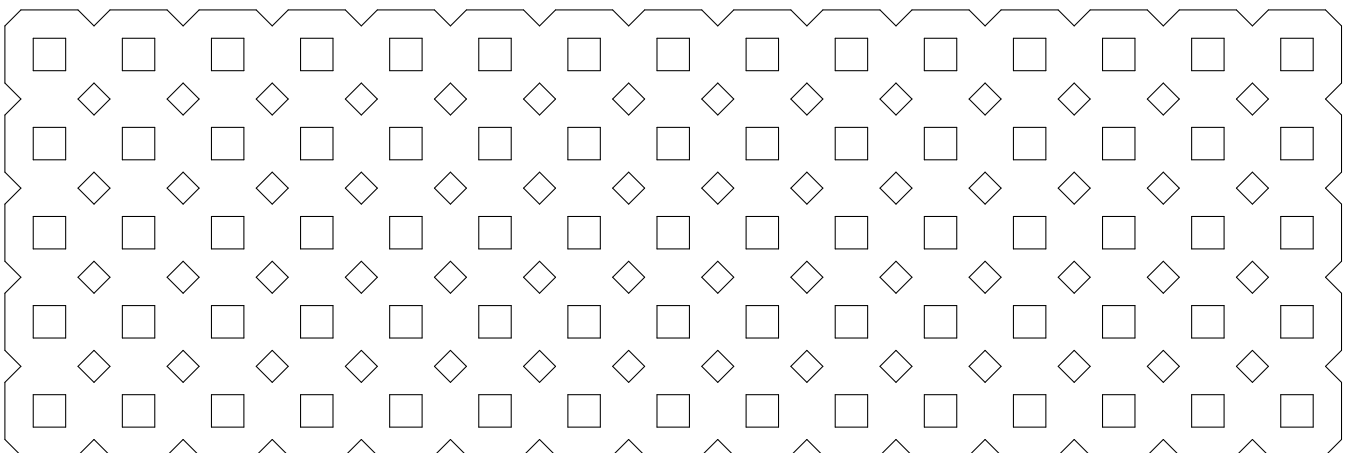

[P15] PLATE, 5 X 15 HOLE

OLE

20 HOLE

25 HOLE

30 HOLE

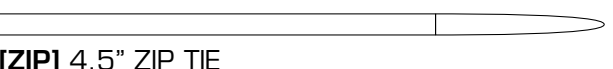
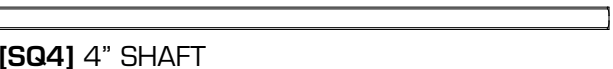
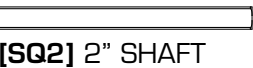
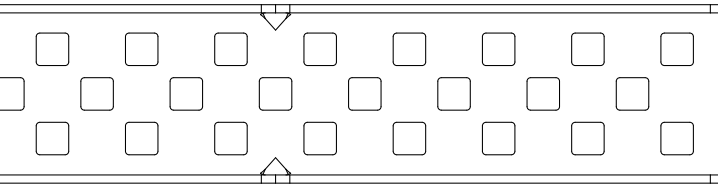
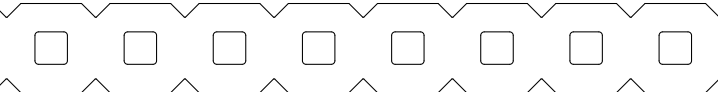

[NK]
8-32 KEPS NUT



[SS2]
1/4" MOTOR SCREW



[SP2]
SPACER THICK



[S2]
1/4" SCREW



[SP1]
SPACER THIN



[S3]
3/8" SCREW



[COL]
COLLAR



[S4]
1/2" SCREW



[BF]
BEARING FLAT



[BR]
POP RIVETS

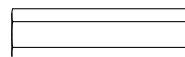

[B1] 1" STANDOFF

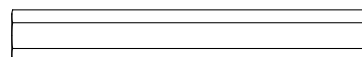

[B2] 2" STANDOFF

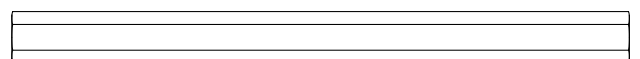

[B3] 3" STANDOFF

Expand and conquer.

Once you've mastered PROTOBOT and TUMBLER, we challenge you to move onto even more advanced robot designs. Of course, all VEX mechanical gears, wheels, hardware and structural metal parts are cross-compatible for endless design possibilities. With hundreds more upgrade parts and accessories, the creative possibilities for your robot designs are limitless. Visit www.VEXROBOTICS.com for more information.

2 Wire Motor 269

SKU 276-2181

\$12.99
MSRP



Tank Tread

SKU 276-2168

\$29.99
MSRP



Gear Kit

SKU 276-2169

\$12.99
MSRP



Omni Wheels

SKU 276-2165

\$19.99
MSRP



Advanced Gear Kit

SKU 276-2184

\$19.99
MSRP



Sprocket and Chain

SKU 276-2166

\$29.99
MSRP



Metal Kit

SKU 276-2161

\$79.99
MSRP

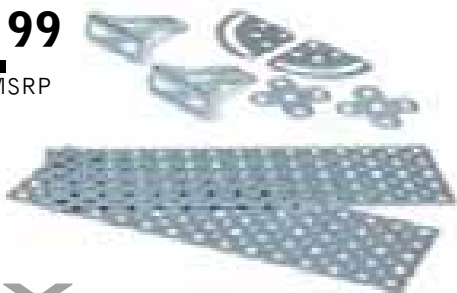

Performance Tool Kit

SKU 276-1645

\$39.99
MSRP



www.VEXROBOTICS.com

GUIDE FOR BUILDING THE **PROTOBOT**

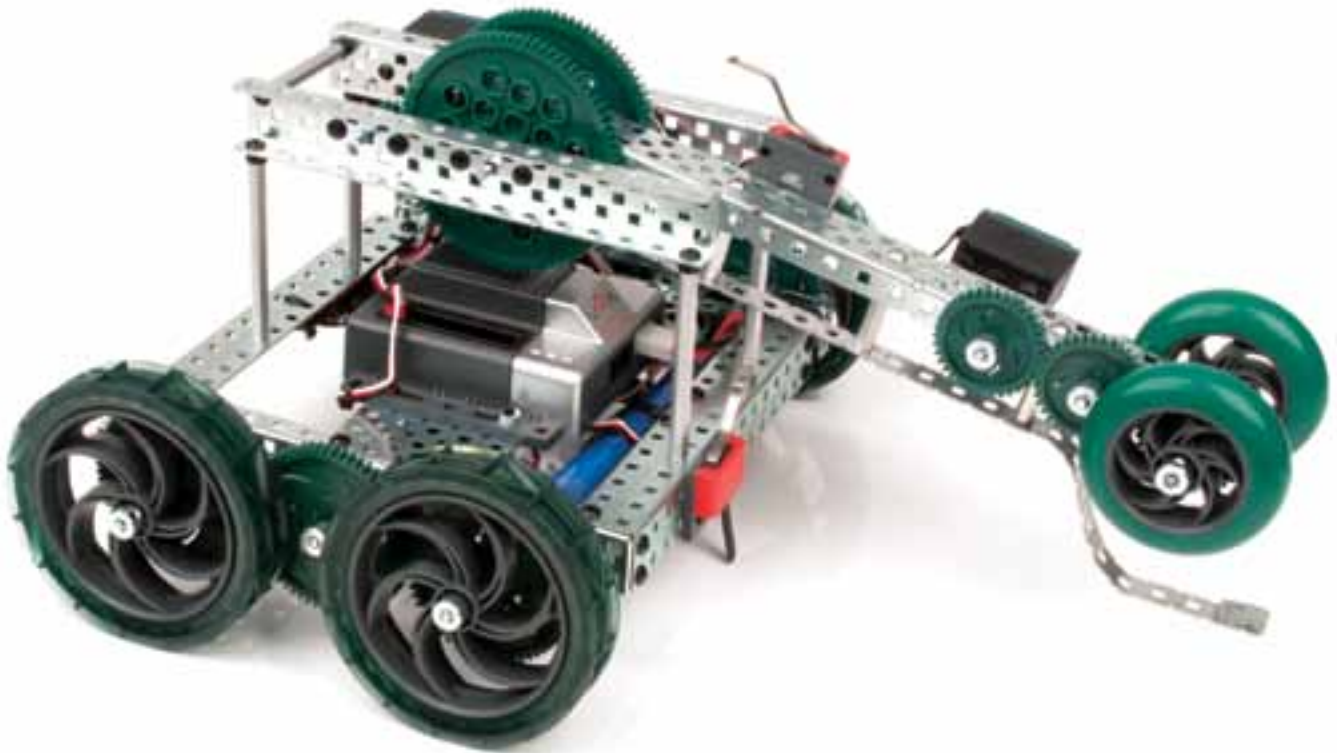

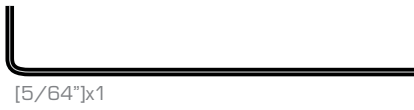

[5/64]x1



[3/32]x1



[WRENCH]x1

1

[SS2] 1/4" MOTOR SCREW

[SS4] 1/2" MOTOR SCREW
[OPTIONAL ACCESSORY]

[5/64]

2

[11/32"] [NK] 8-32 KEPS NUT

[B0.5, 1, 2, 3]

[1/4"]

3

[5/64]

[COL] COLLAR

4

[S2] 1/4" SCREW

[S3] 3/8" SCREW

[S4] 1/2" SCREW

[3/32"]

5

[BR] POP RIVETS

[BF] BEARING FLAT

6

[BF] BEARING FLAT



[5/64"]x1



[3/32"]x1



[WRENCH]x1

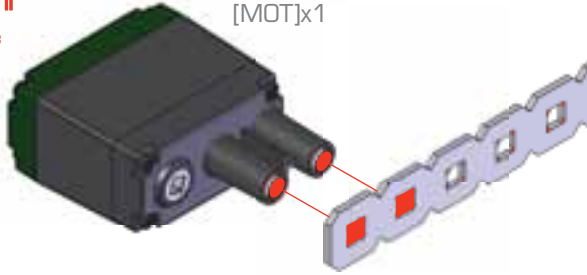

[MOT]x1



3-WIRE MOTOR

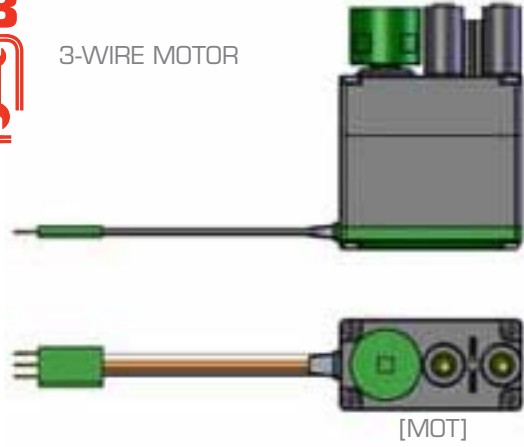

[MOT]



2-WIRE MOTOR WITH MOTOR CONTROLLER 29

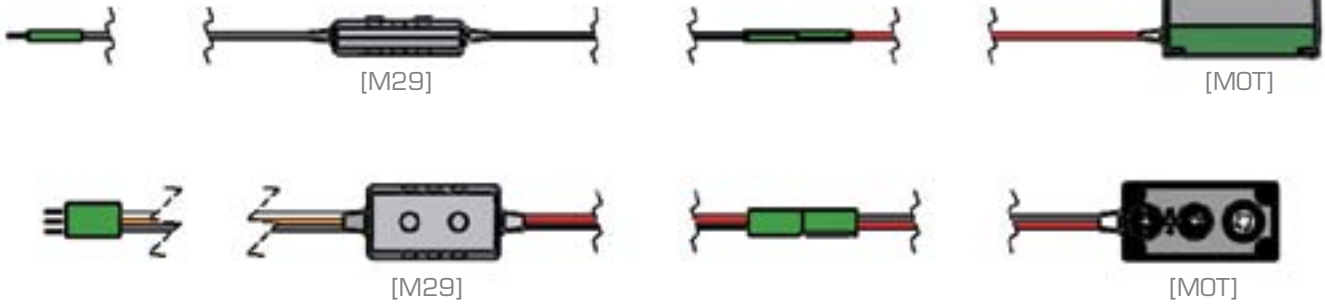

[M29]

[MOT]

[M29]

[MOT]

1

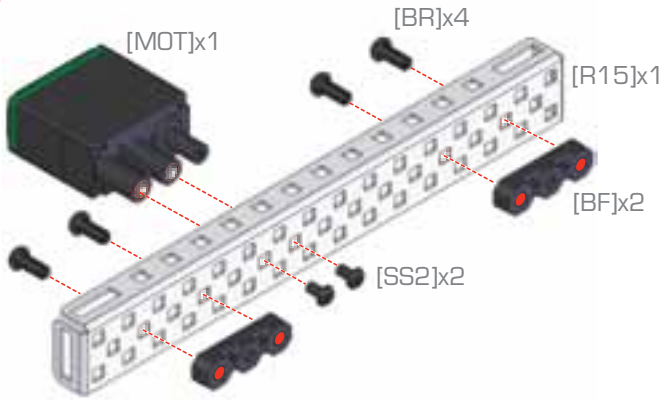

2

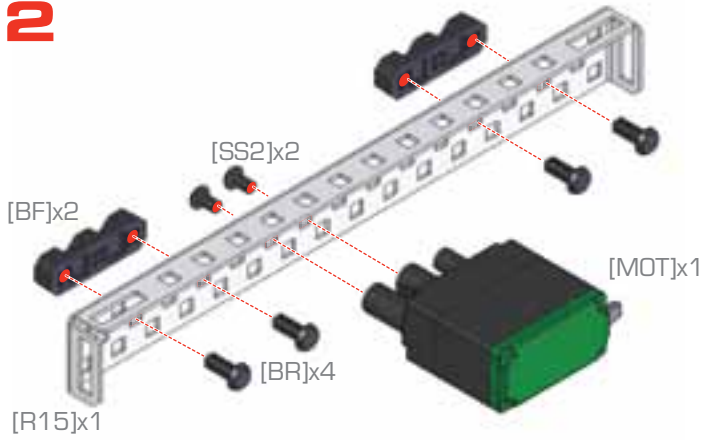

3

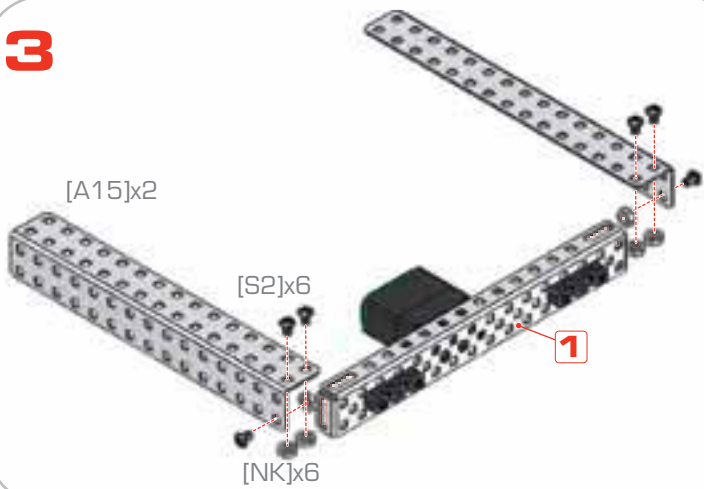

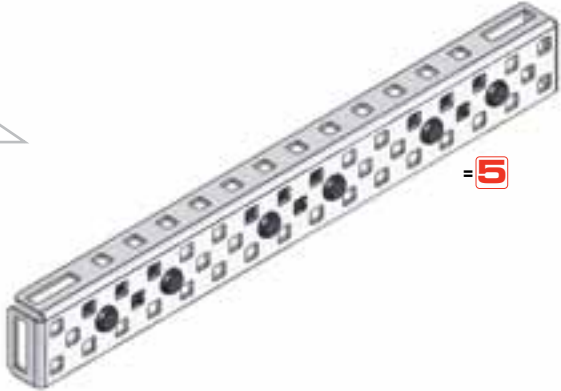
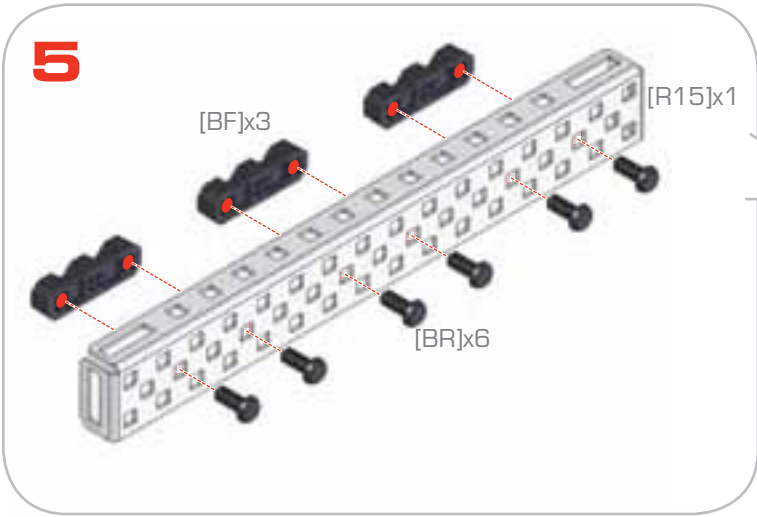
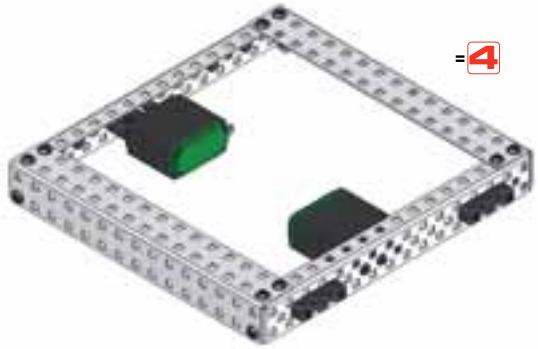
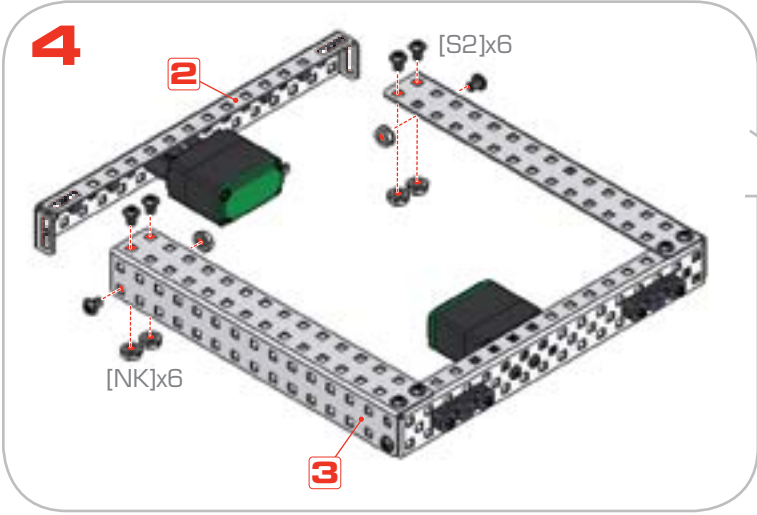

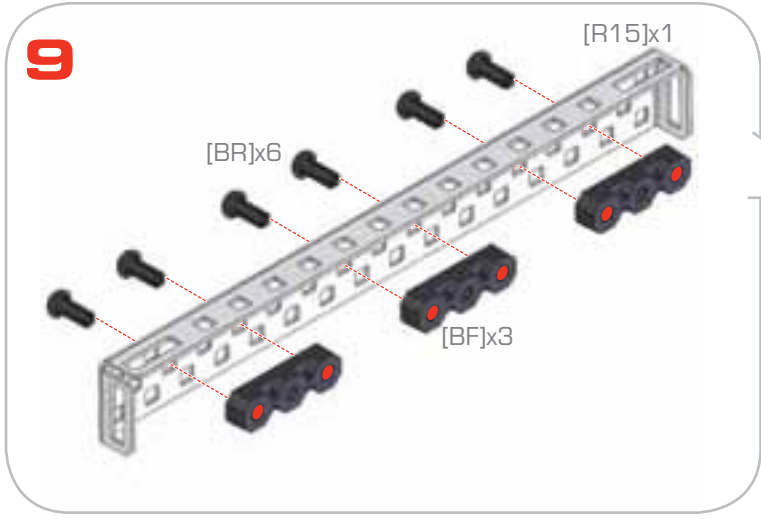
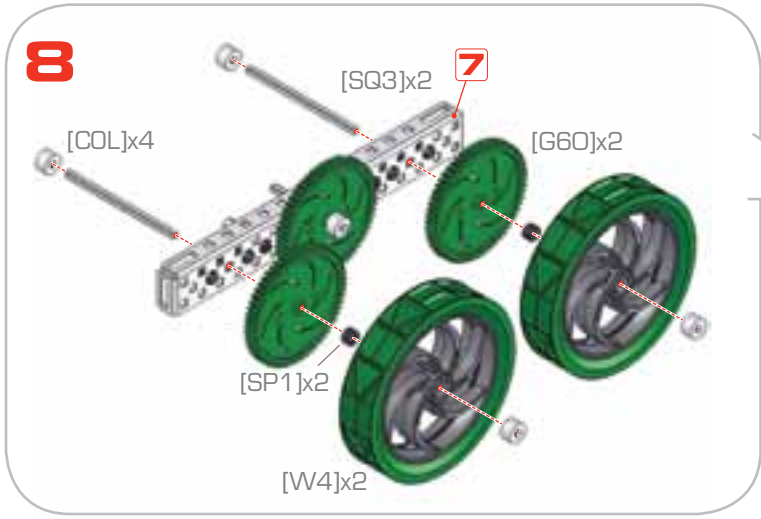
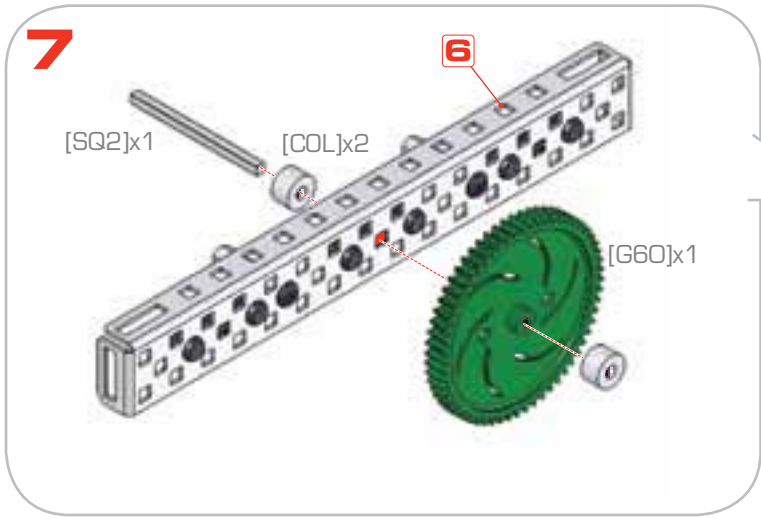

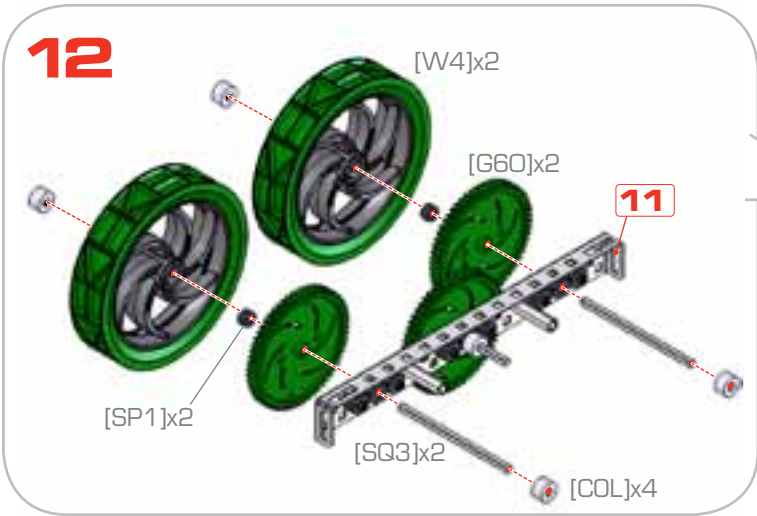
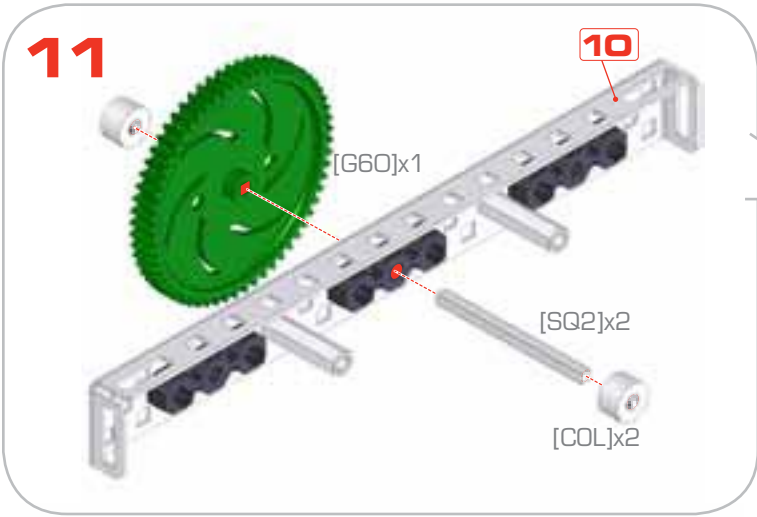
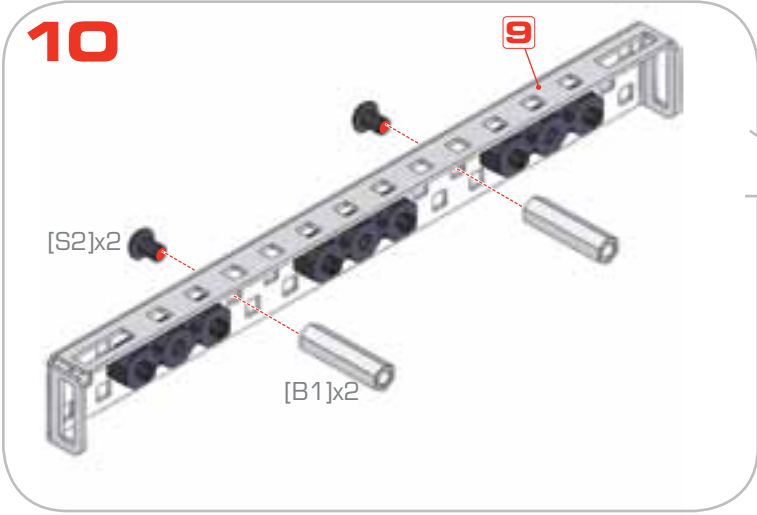

13

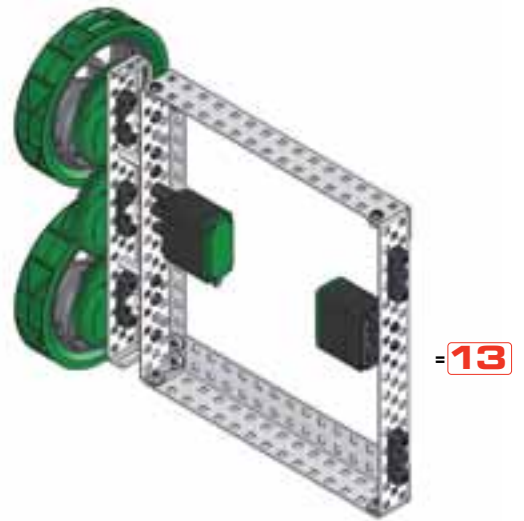
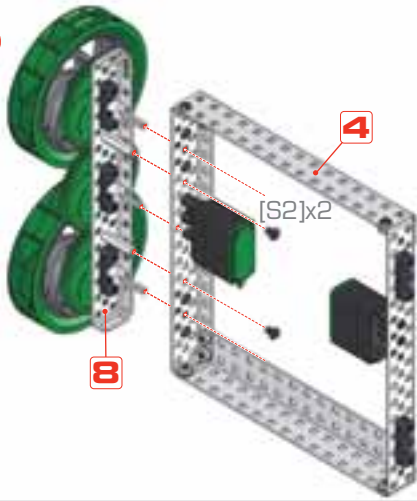

14

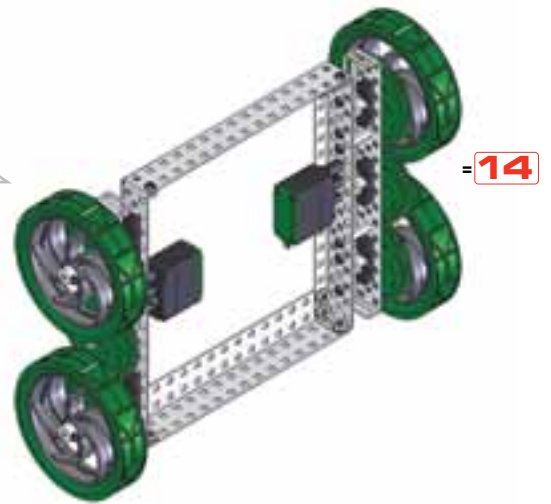
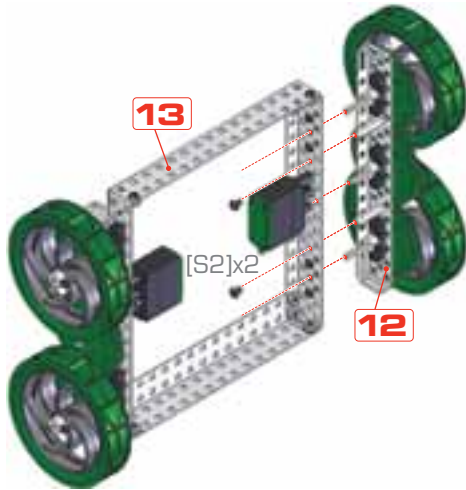

15

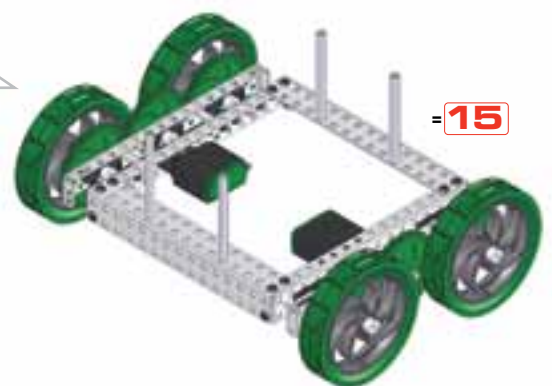
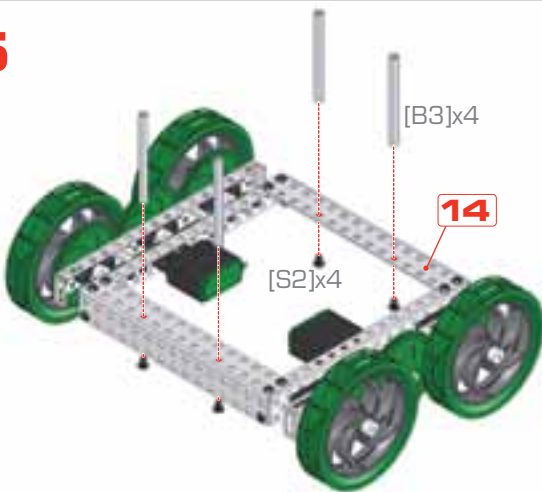

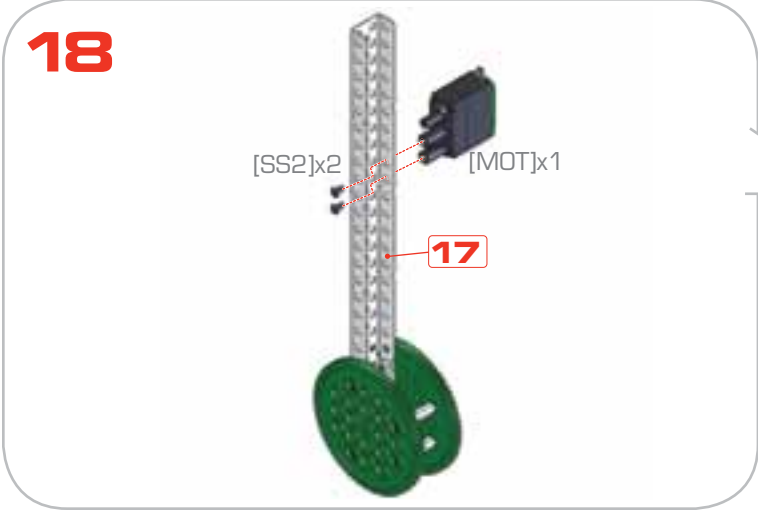
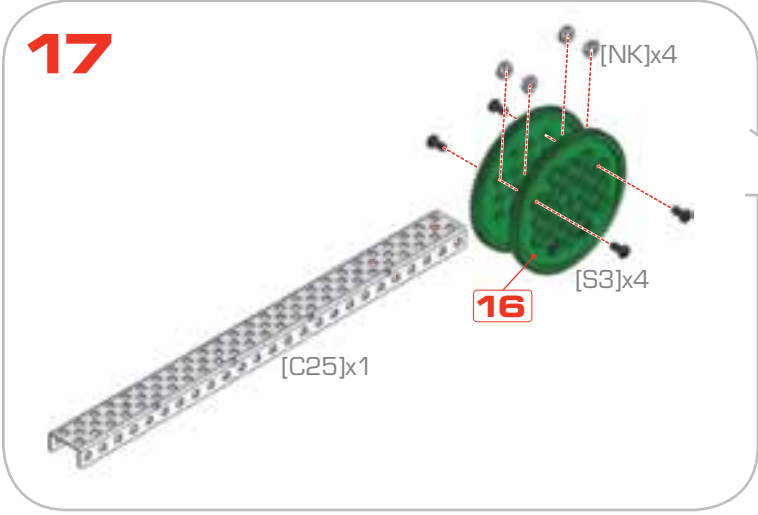
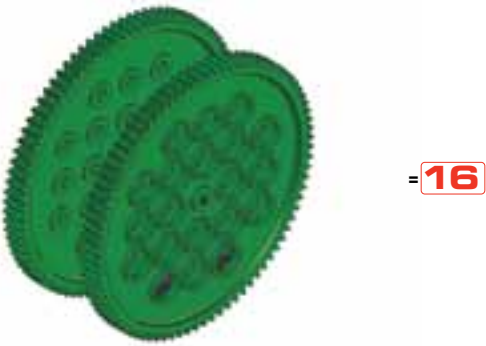
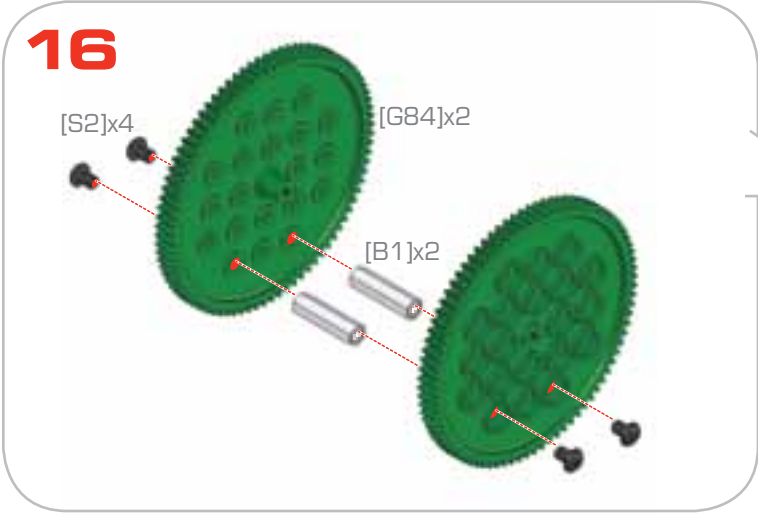

19

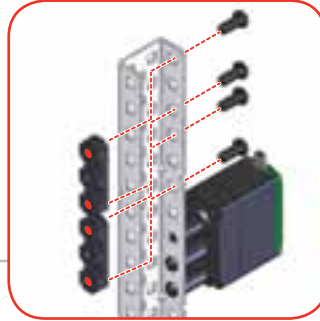
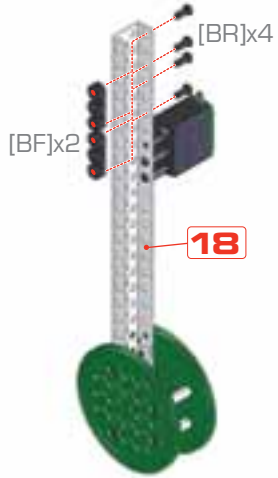

20

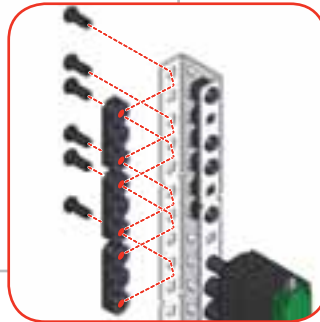
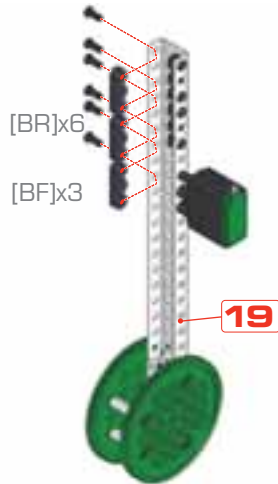

21

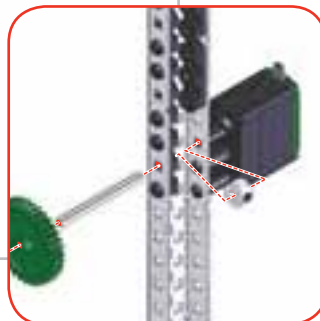
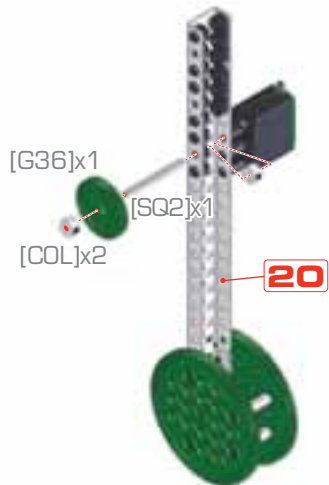

22

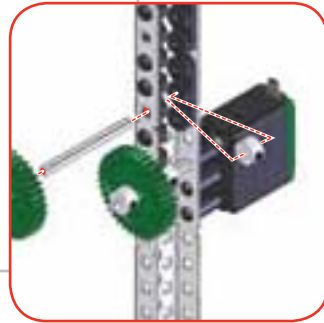
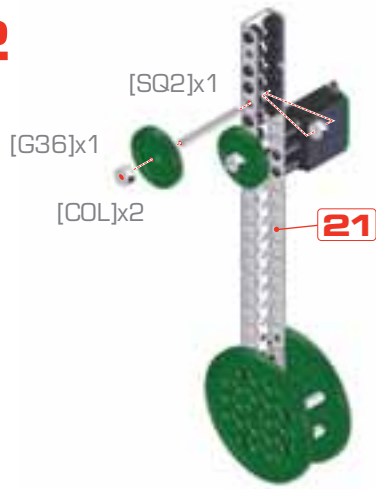

22

23

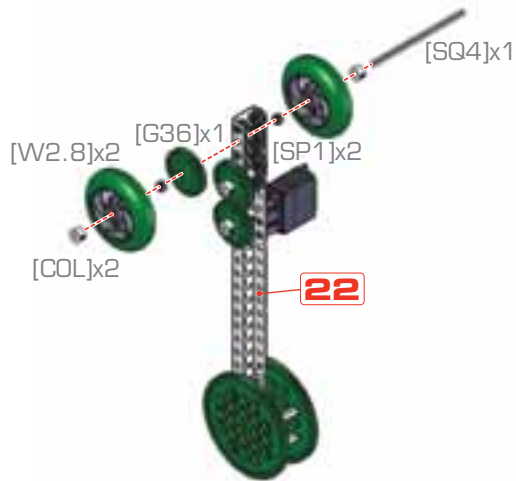

23

24

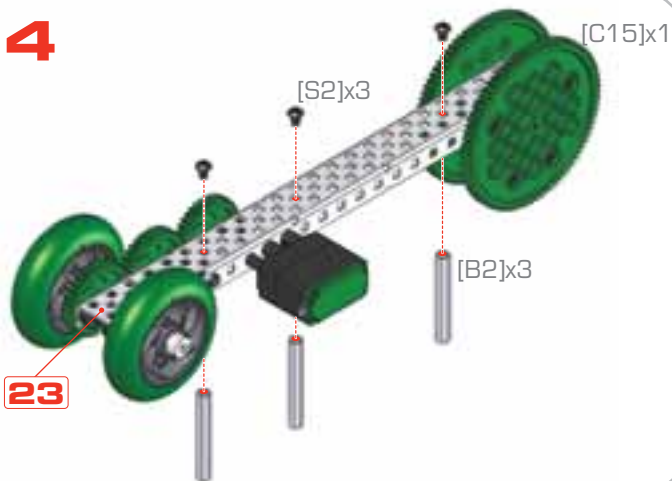

24

25

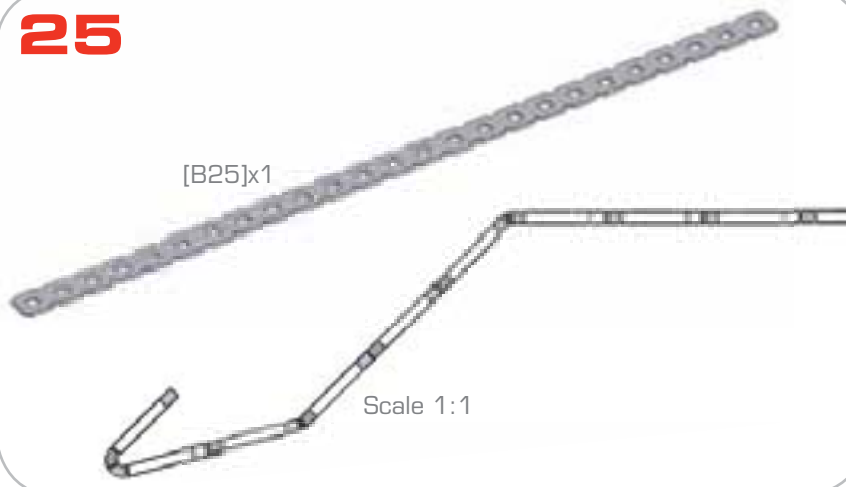

26

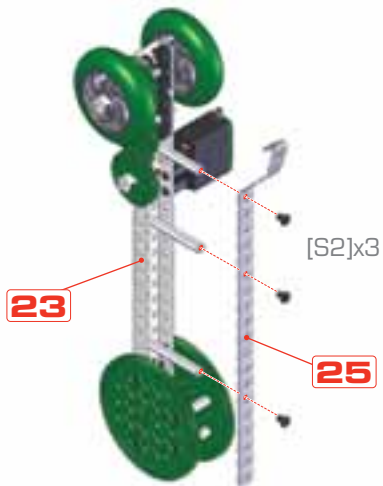

27

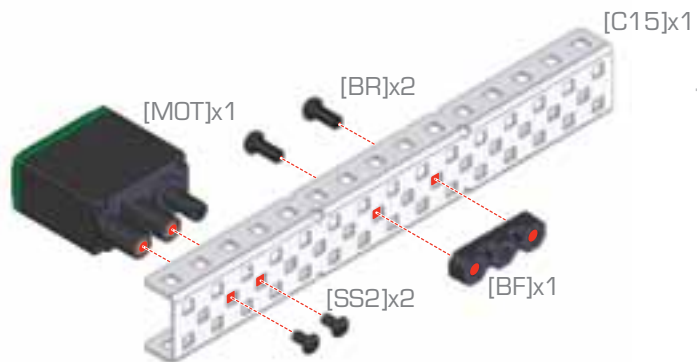

28

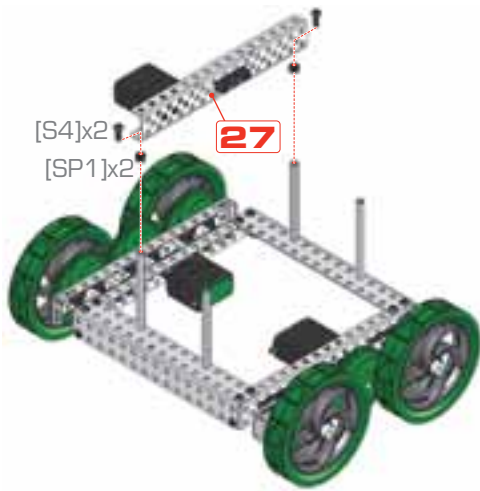

29

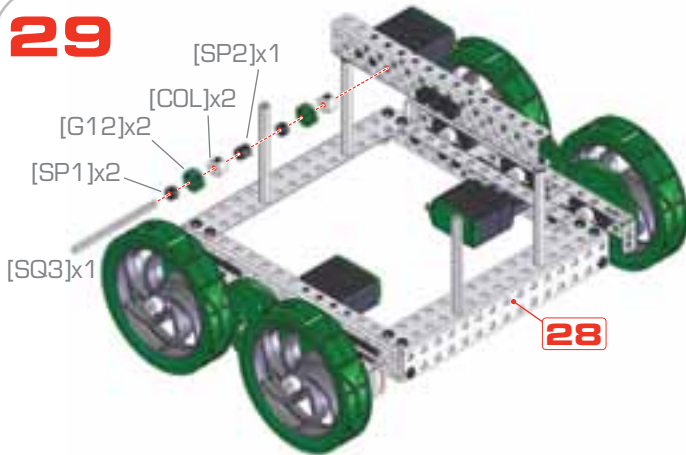

30

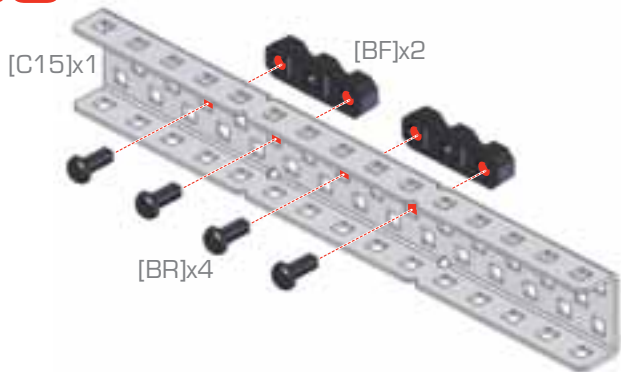

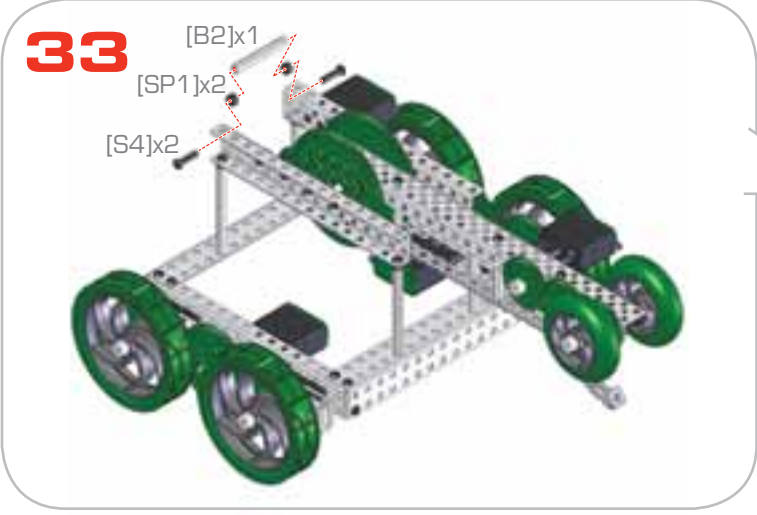
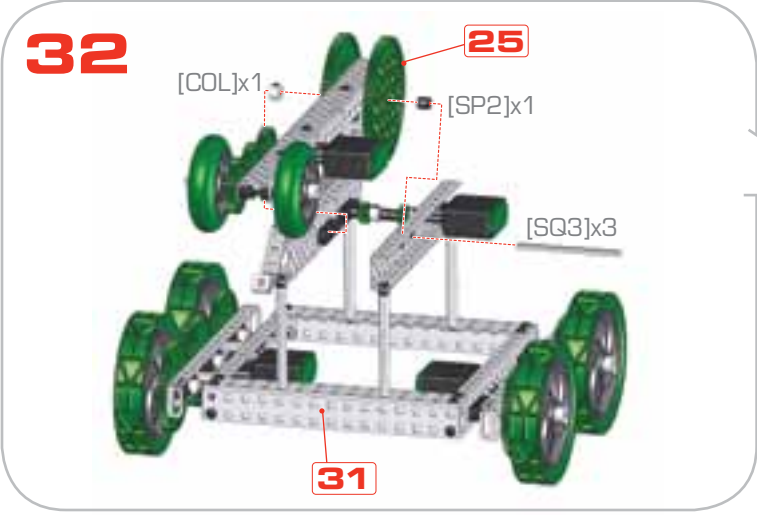
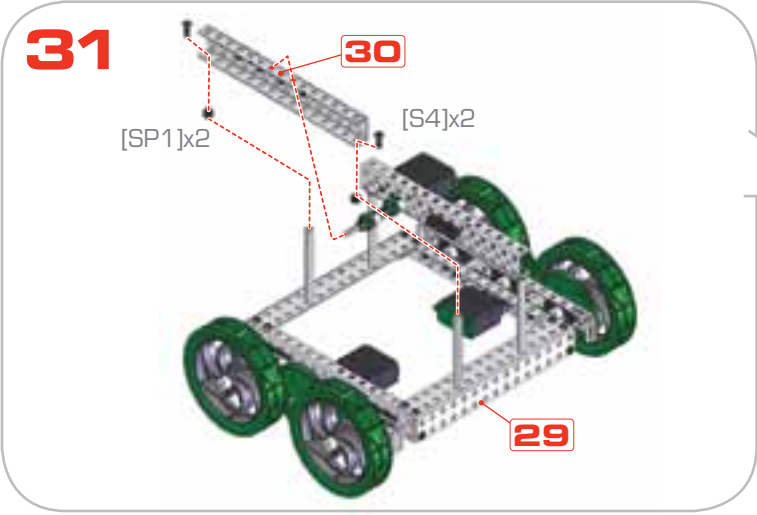

34-38

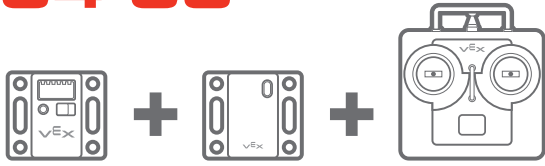

[OPTIONAL]
OR SKIP TO 39

34

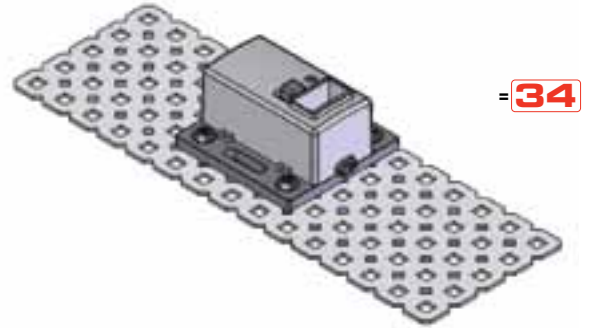
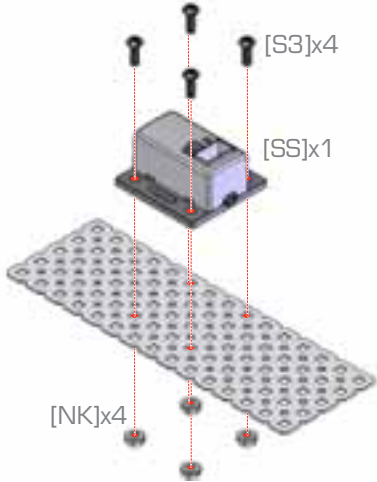

35

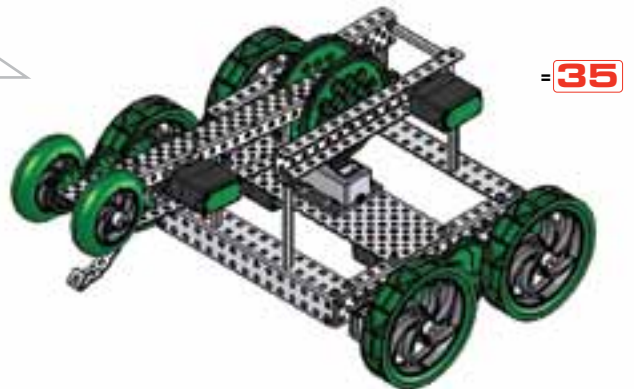
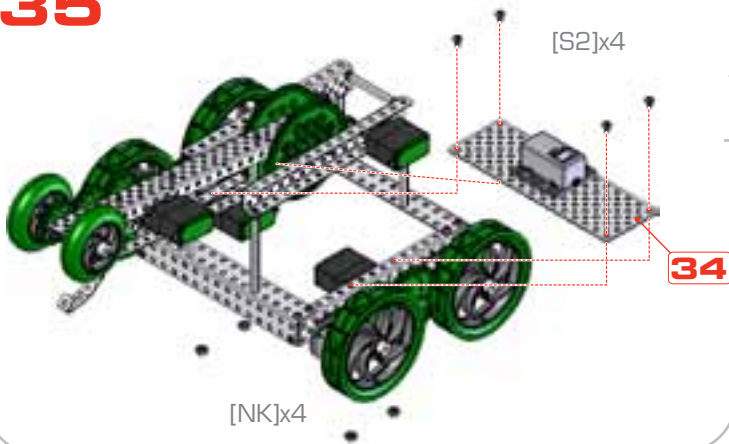

36

[S3]x2

[NK]x2

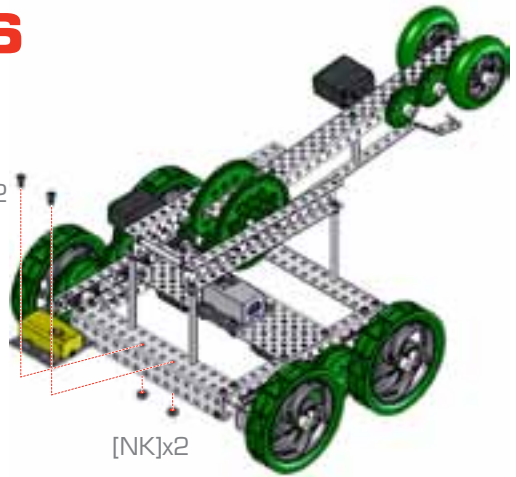

= **36**

37

[S3]x1

[AH]x1

[NK]x1

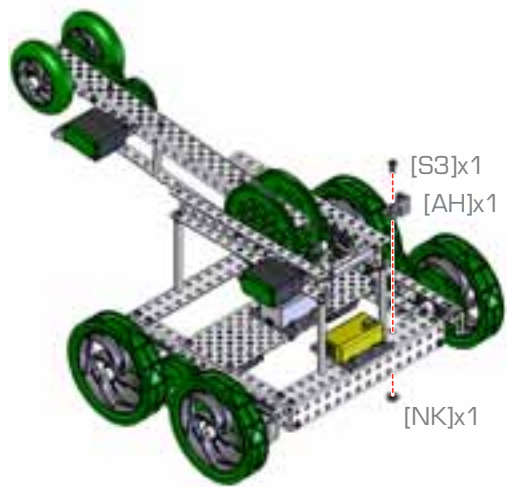

= **37**

38

[AT]x1

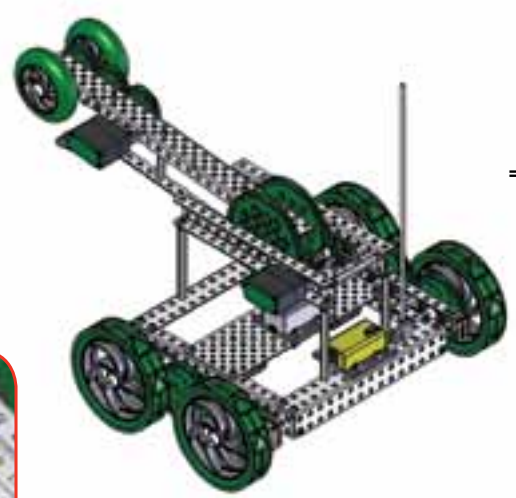
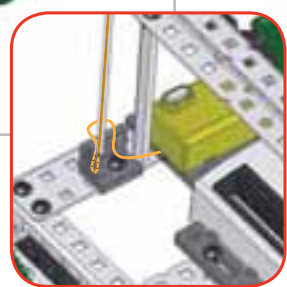
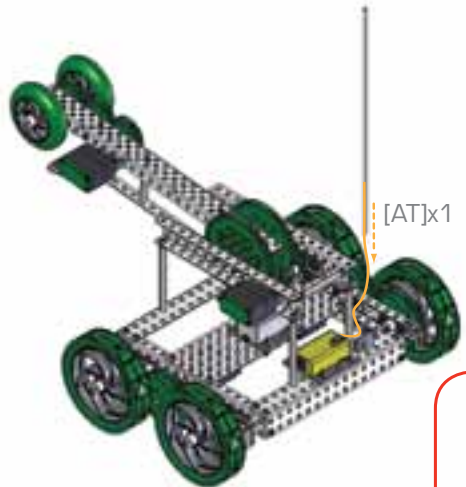

= **38**

39-40



X2

**[OPTIONAL]
OR SKIP TO 41**

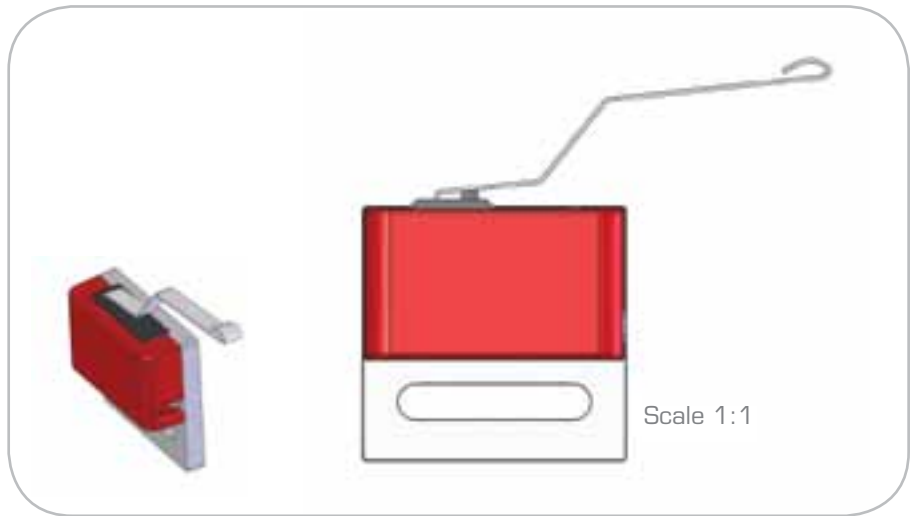
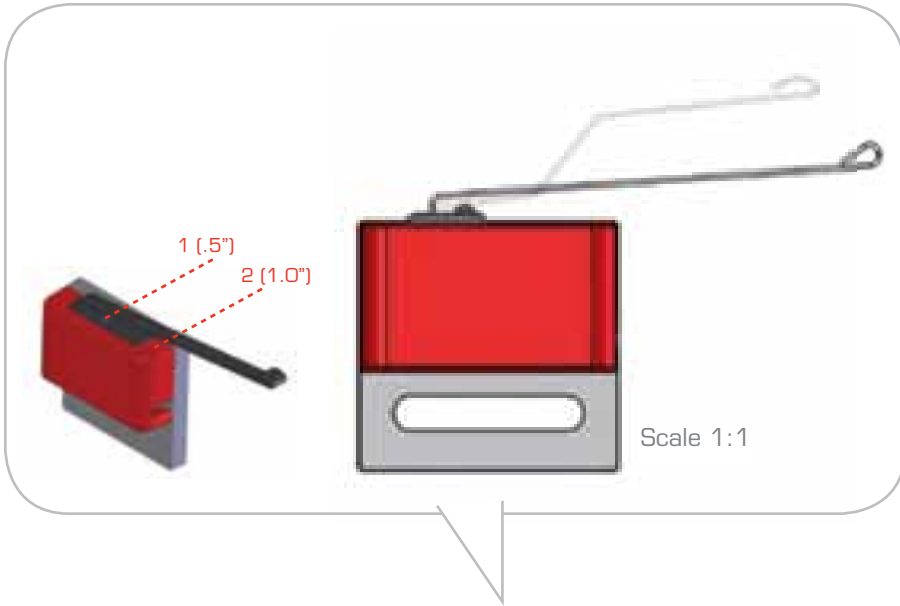

39

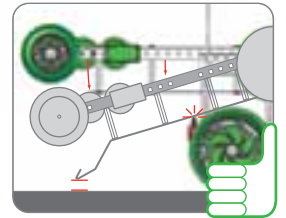

40

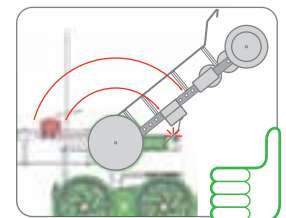
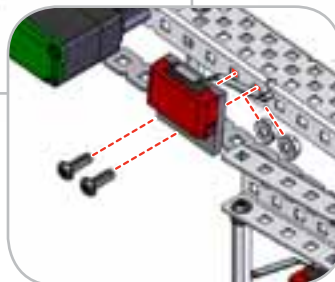
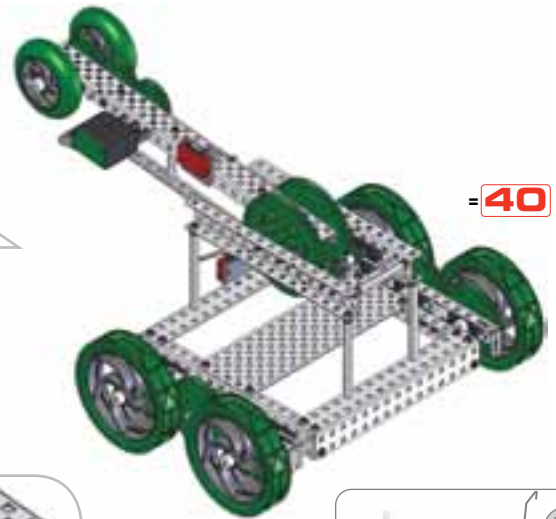
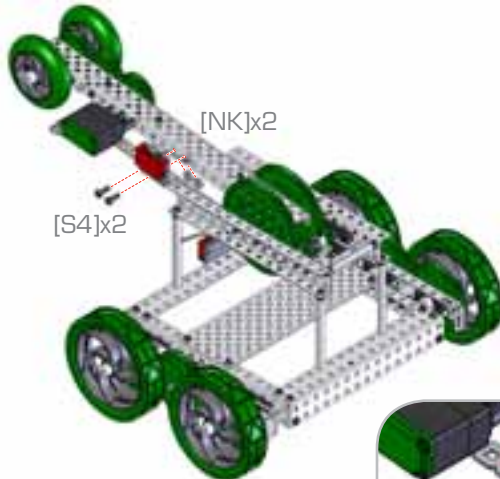

41-42



x1

[OPTIONAL]
OR SKIP TO 43

41

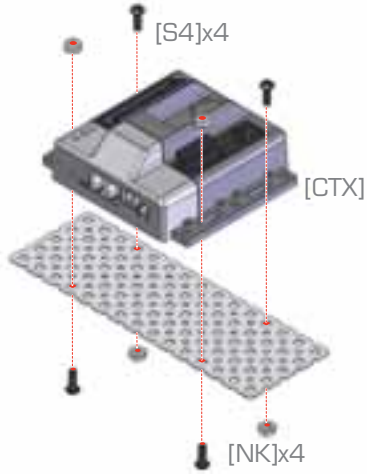

= 41

42

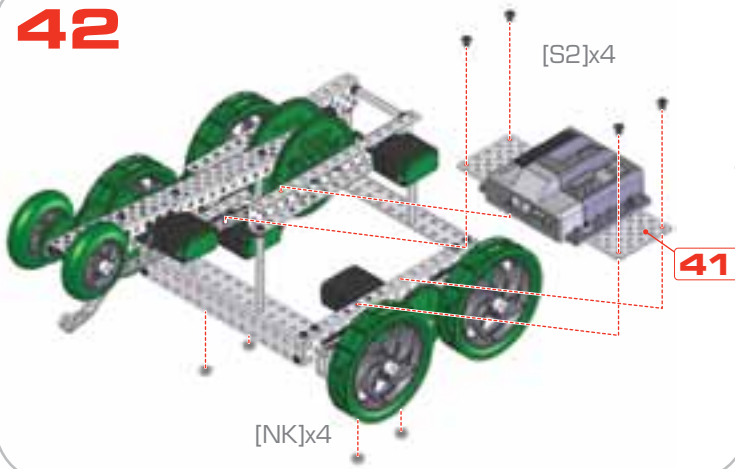

= 42

43-44



[OPTIONAL]
OR SKIP TO 45

43

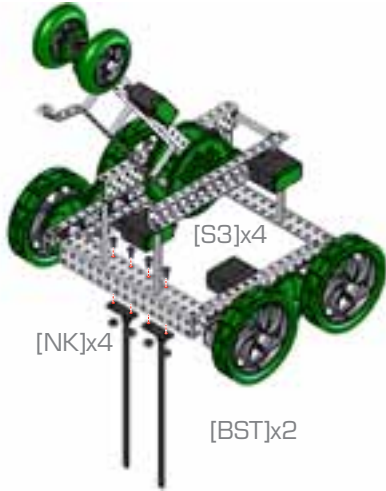

= 43

44

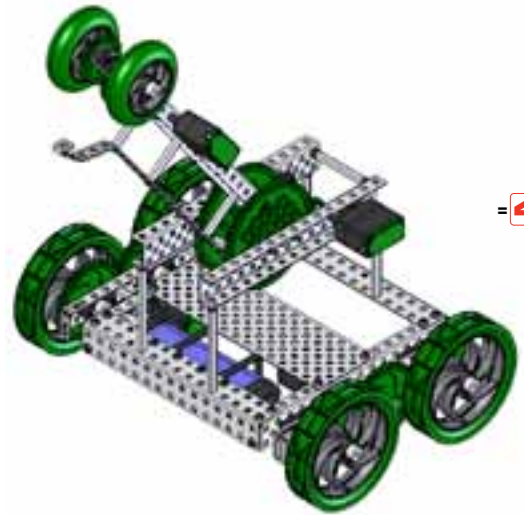
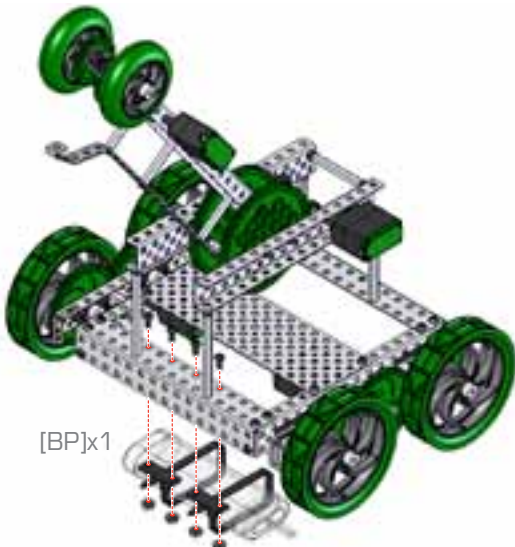

= 44

45



X1 [OPTIONAL]
OR SKIP TO 46

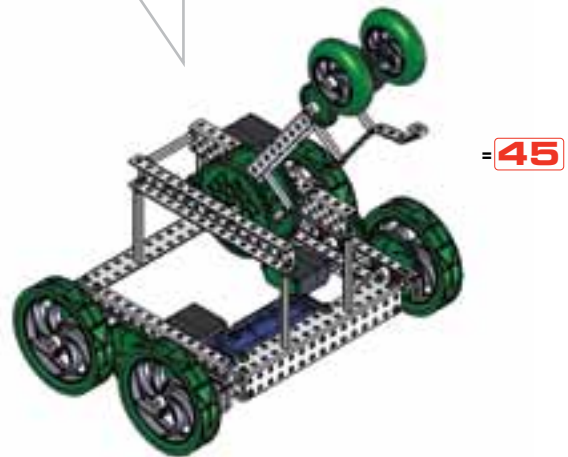
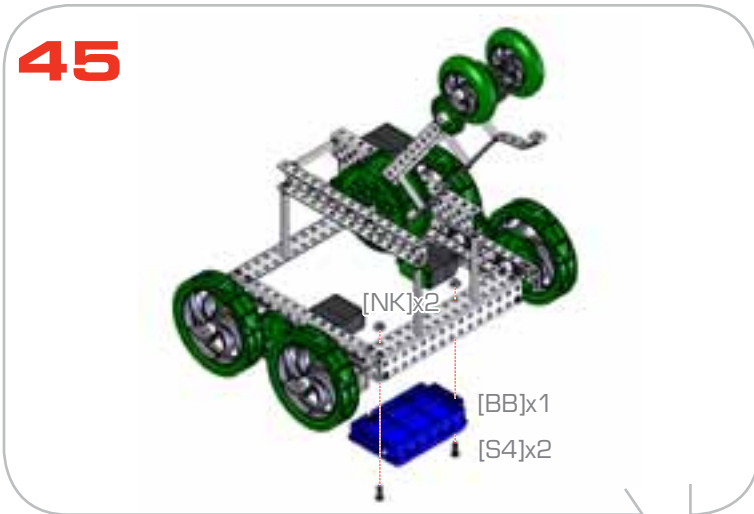

46-50



X1 [OPTIONAL]
OR SKIP TO WIRING

46

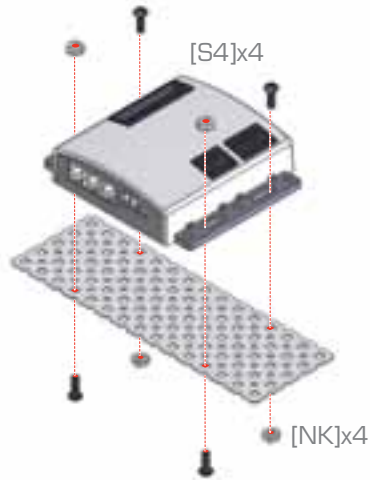

47

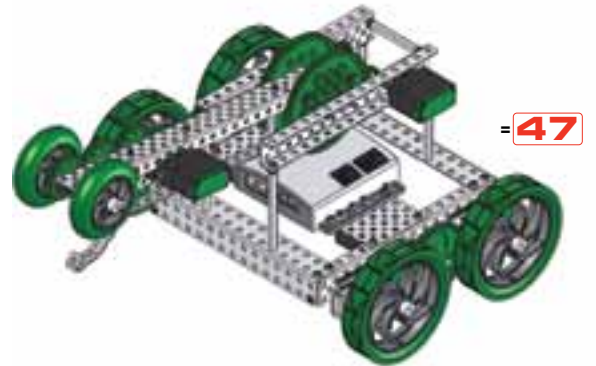
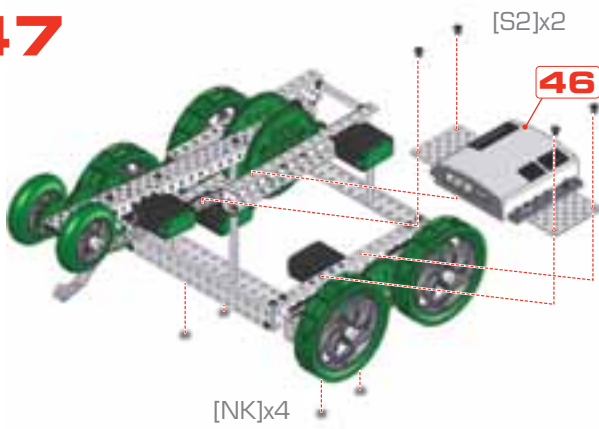

48

[S3]x2
[RX75]x1
[NK]x2

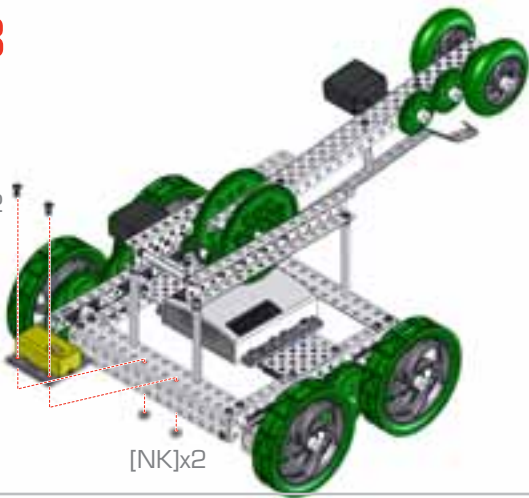

48

49

[S3]x1
[AH]x1
[NK]x1

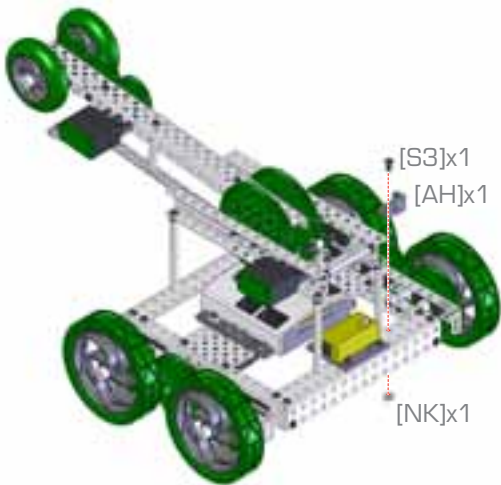

49

50

[AT]x1

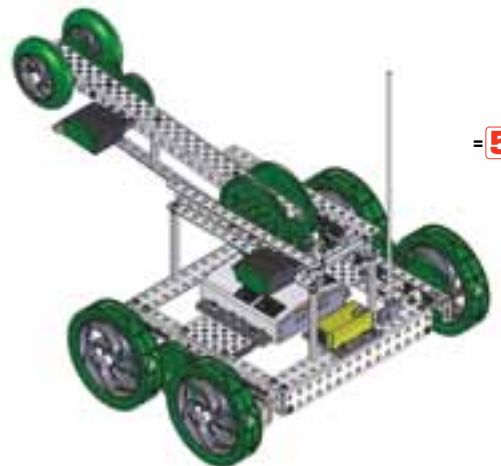
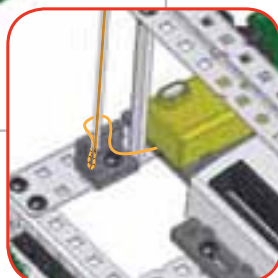
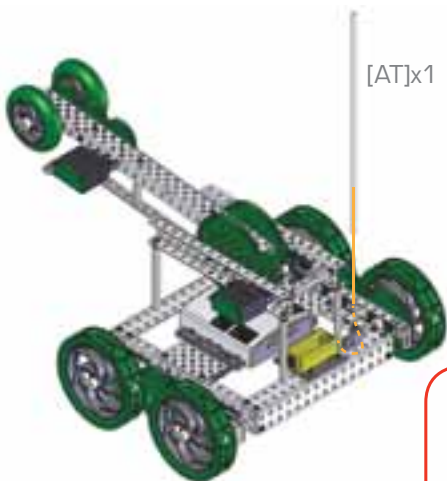

50

[VMC] WIRING

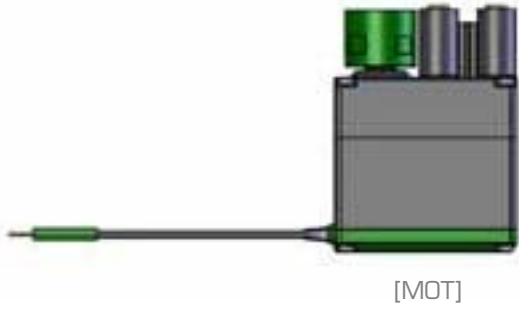

OR

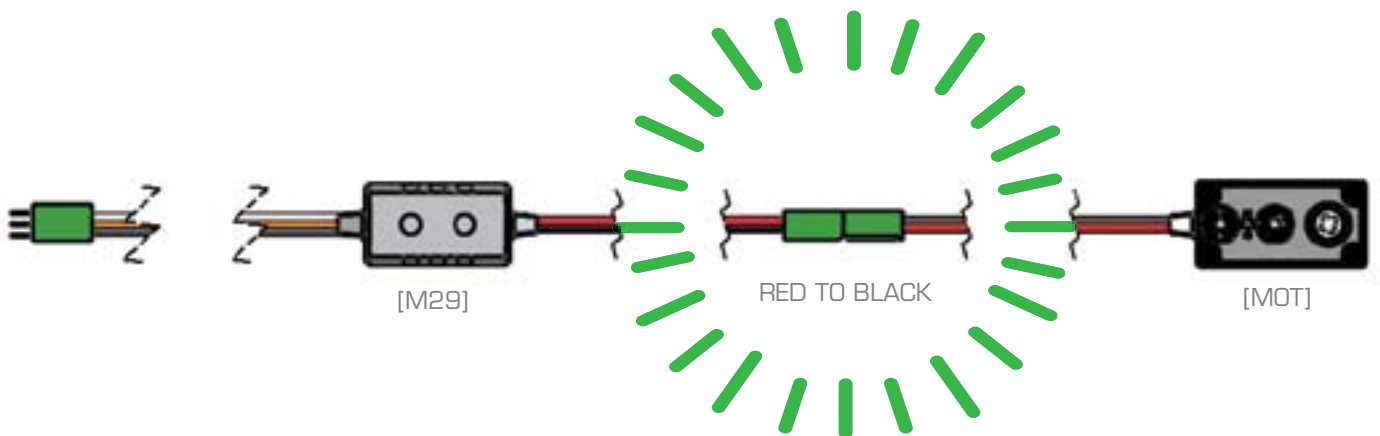
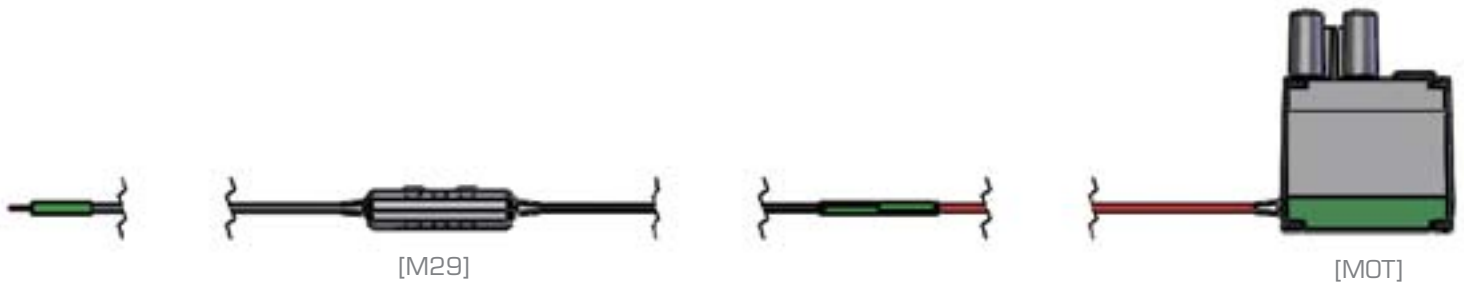

[SSX] WIRING

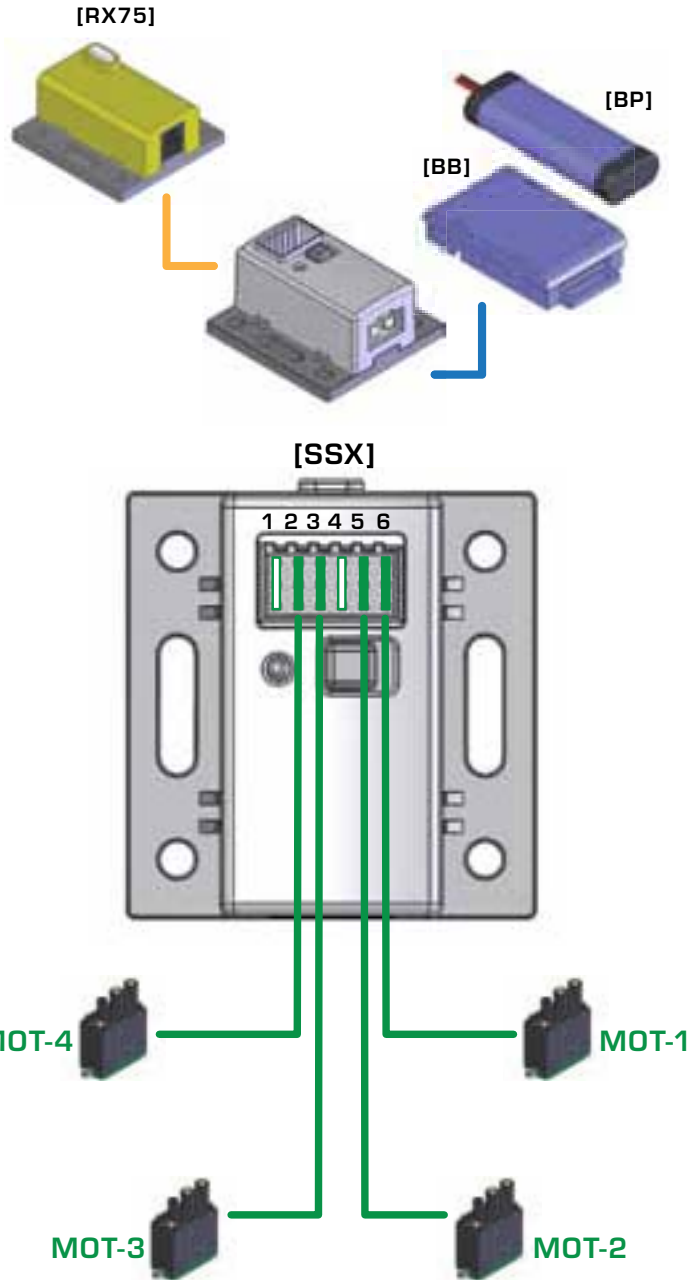
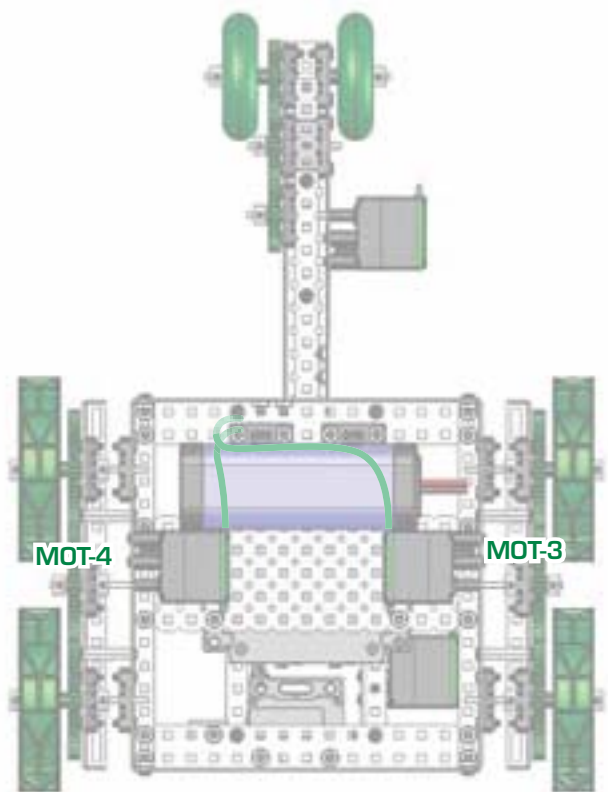
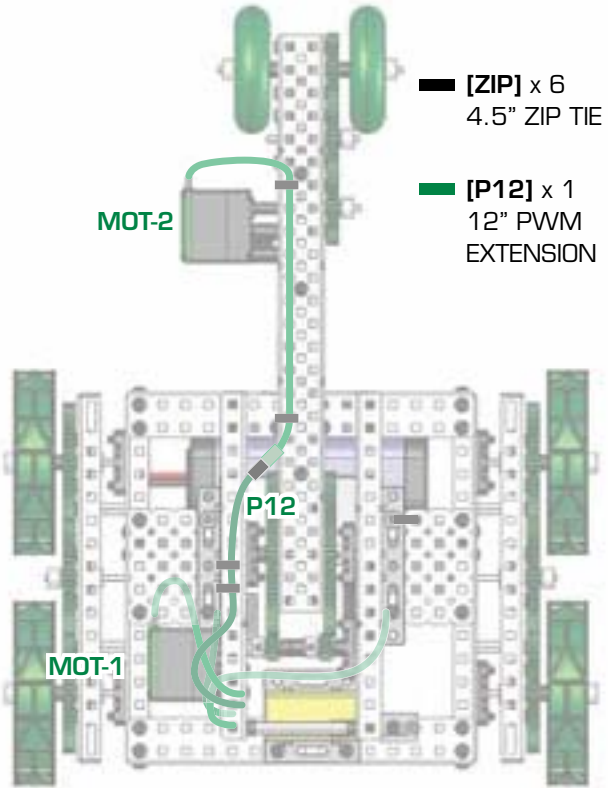

[CTX] WIRING

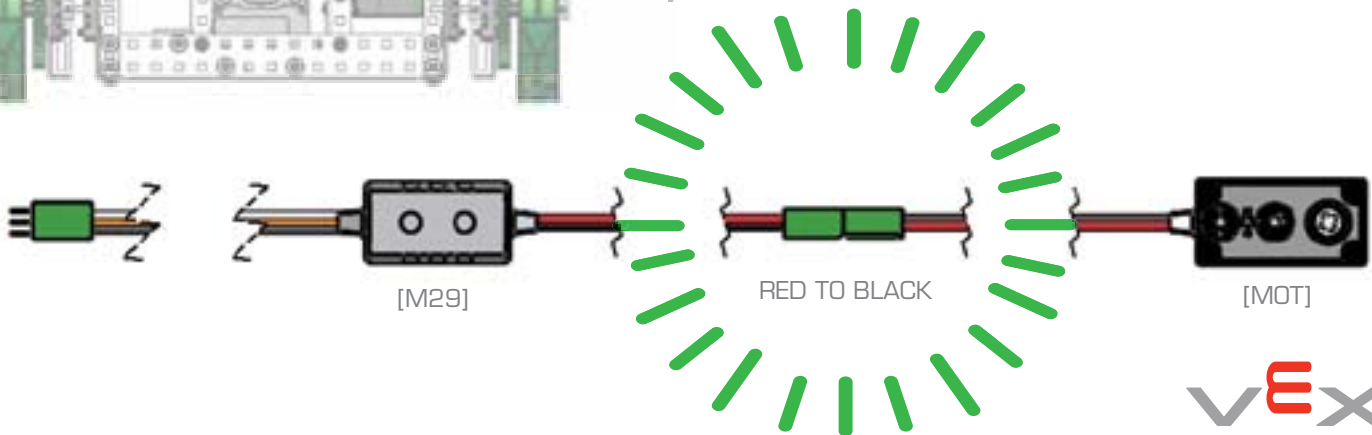
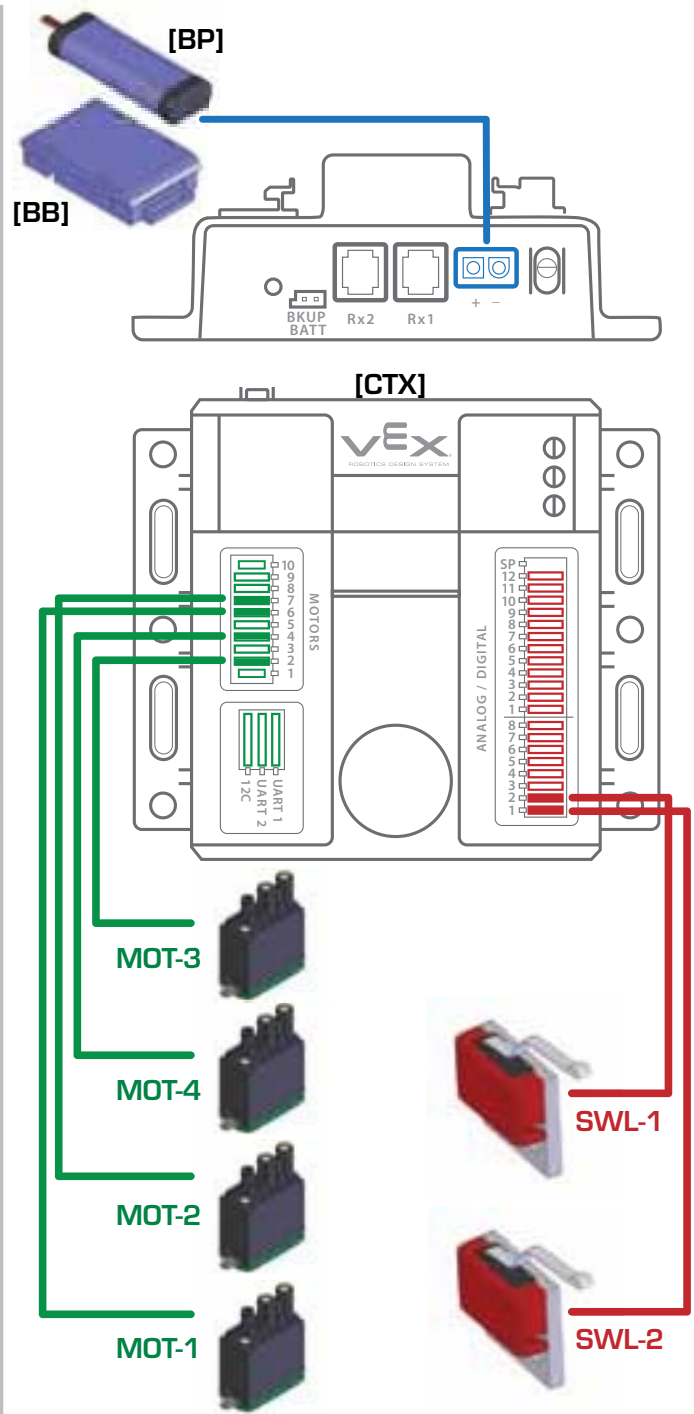
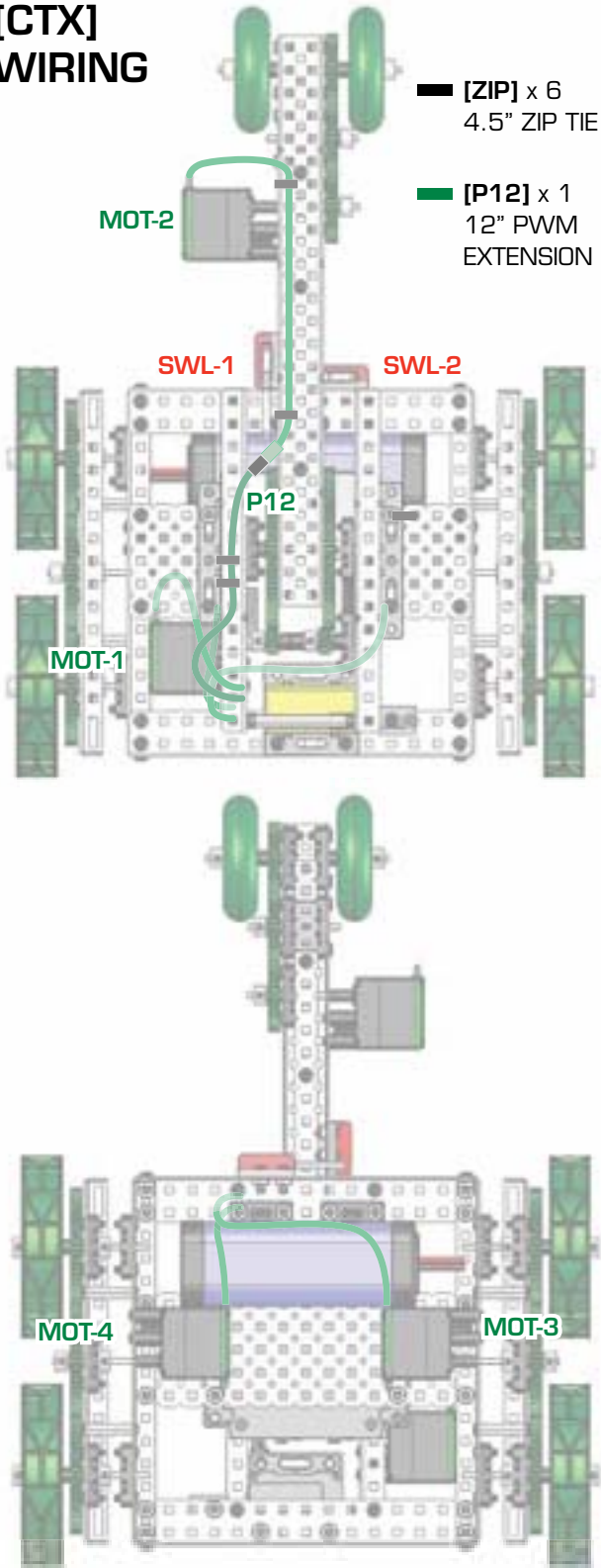

[VMC] WIRING

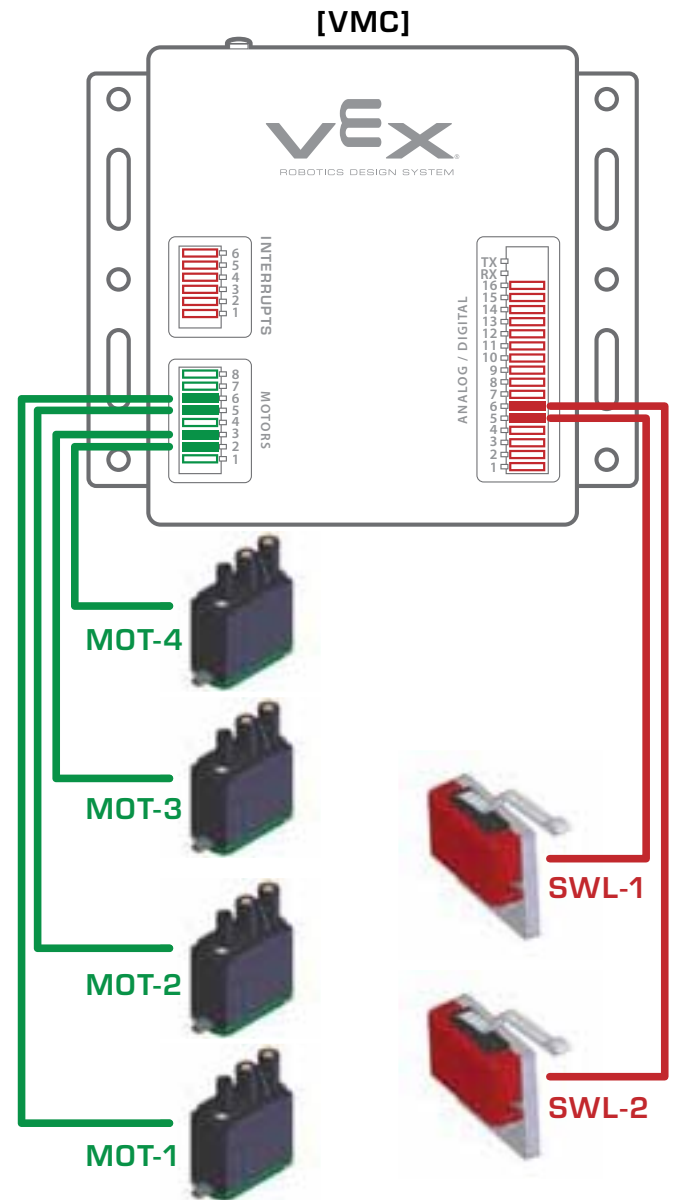
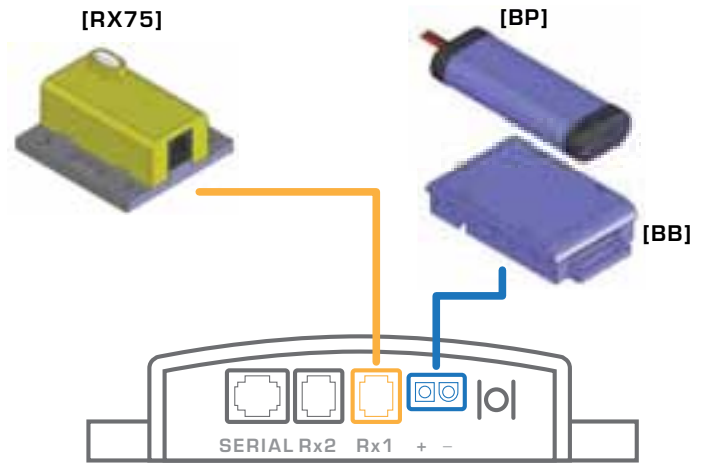
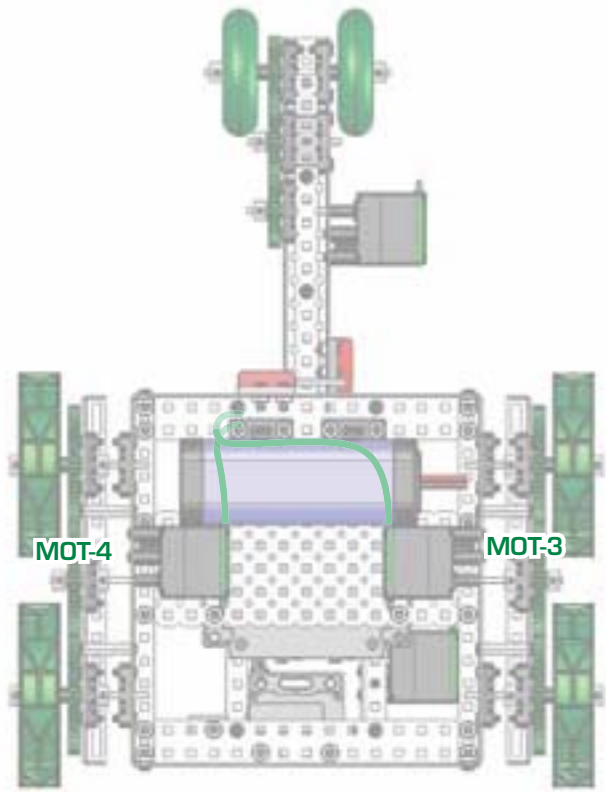
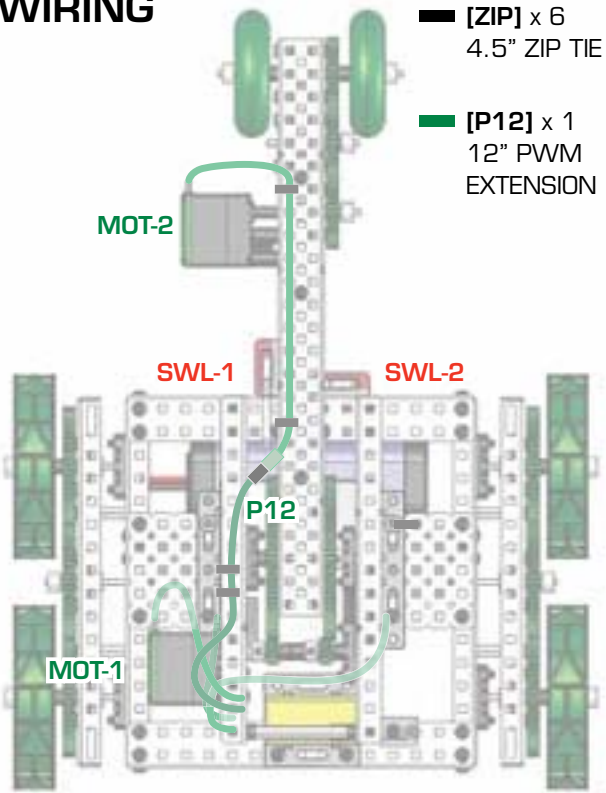

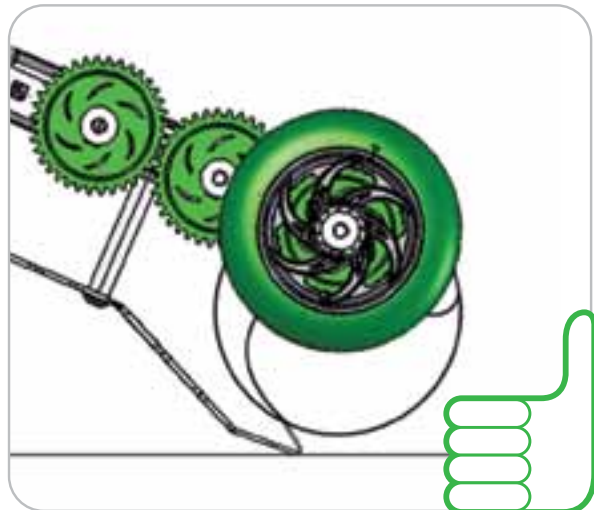
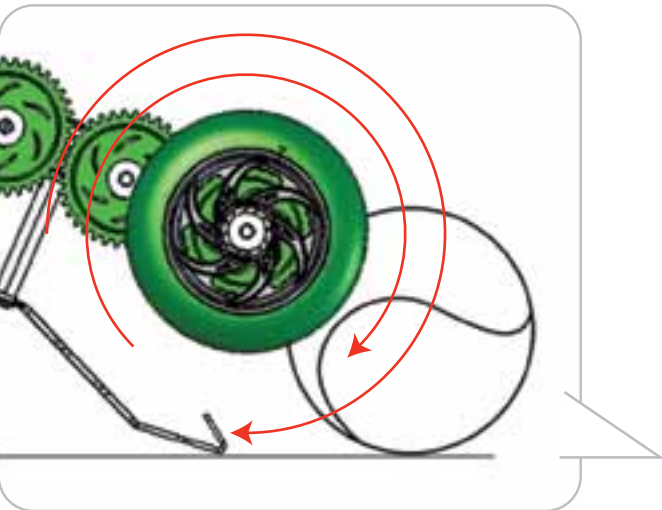
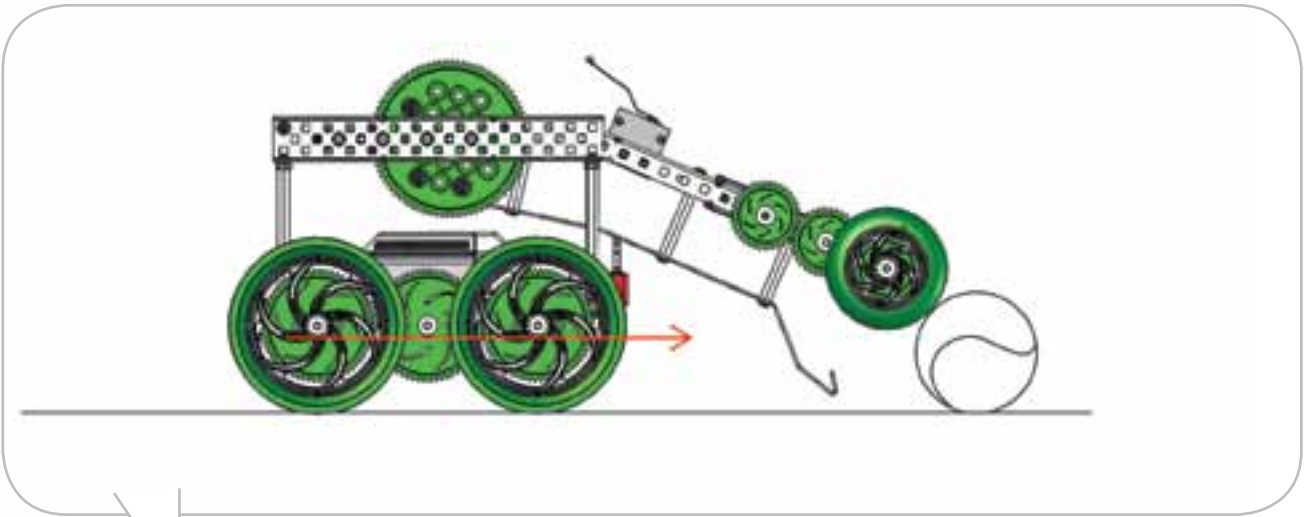
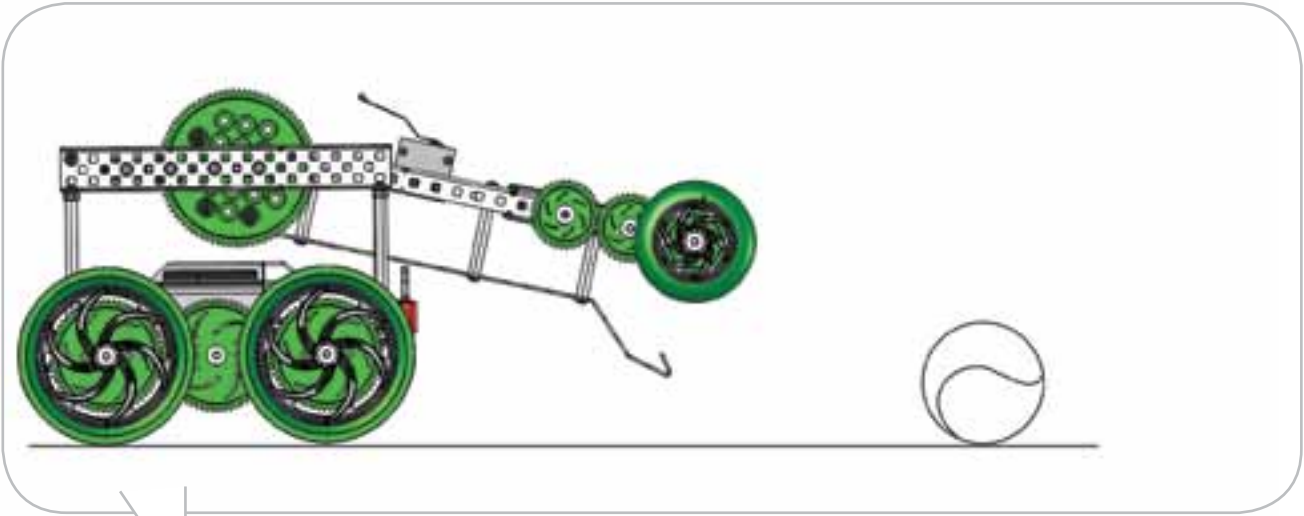

GUIDE FOR BUILDING THE **TUMBLER**

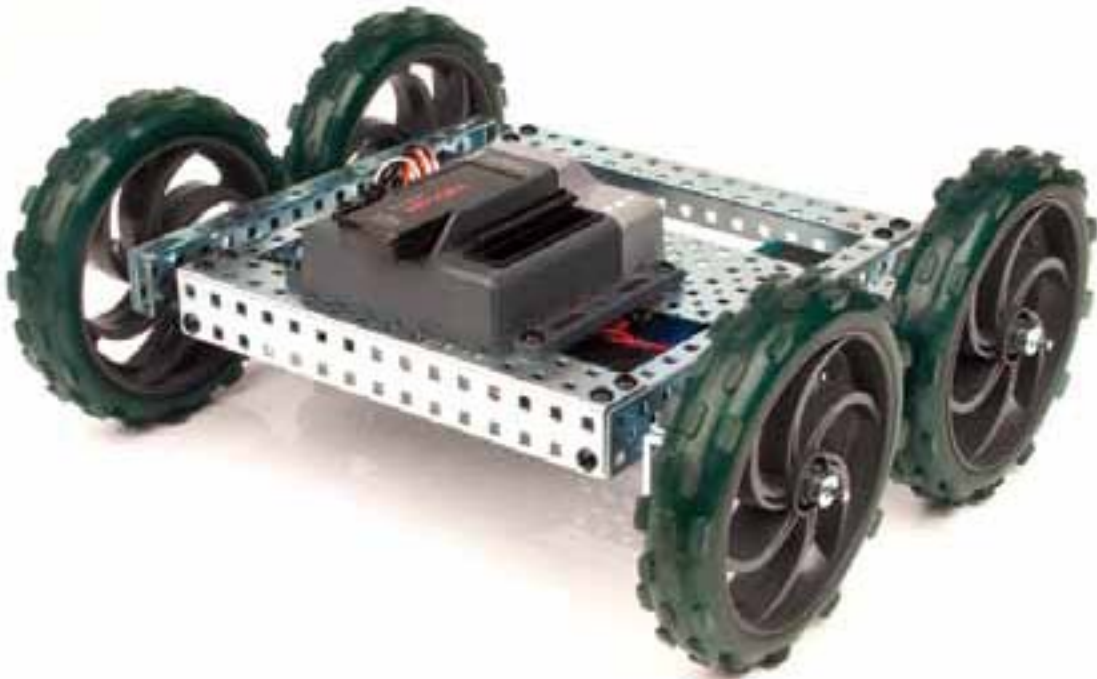



5 HOLE

10 HOLE

15 HOLE

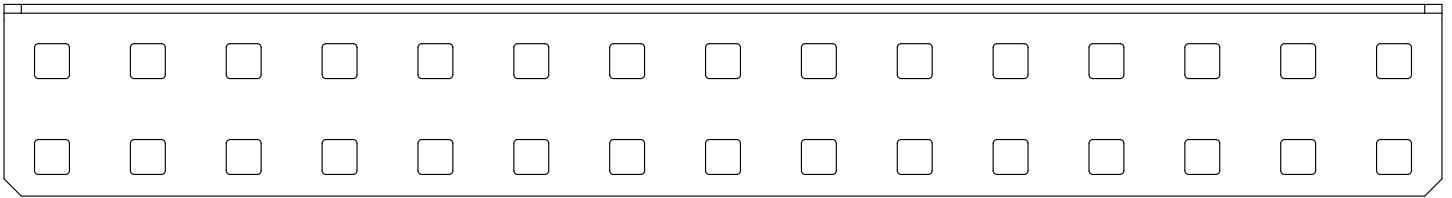

[A15] CHASSIS BUMPER, 15 HOLE

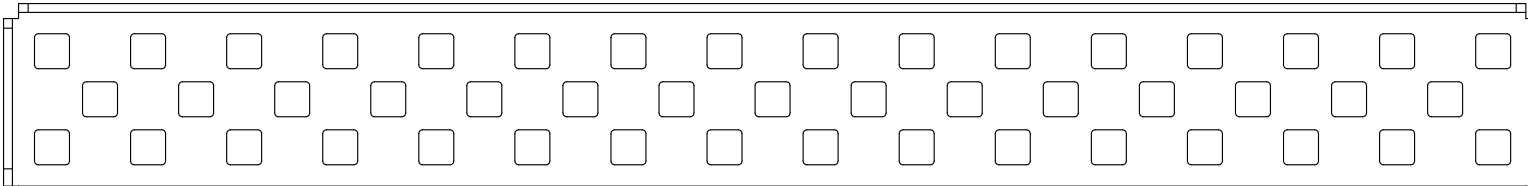

[R15] CHASSIS RAIL, 16 HOLE

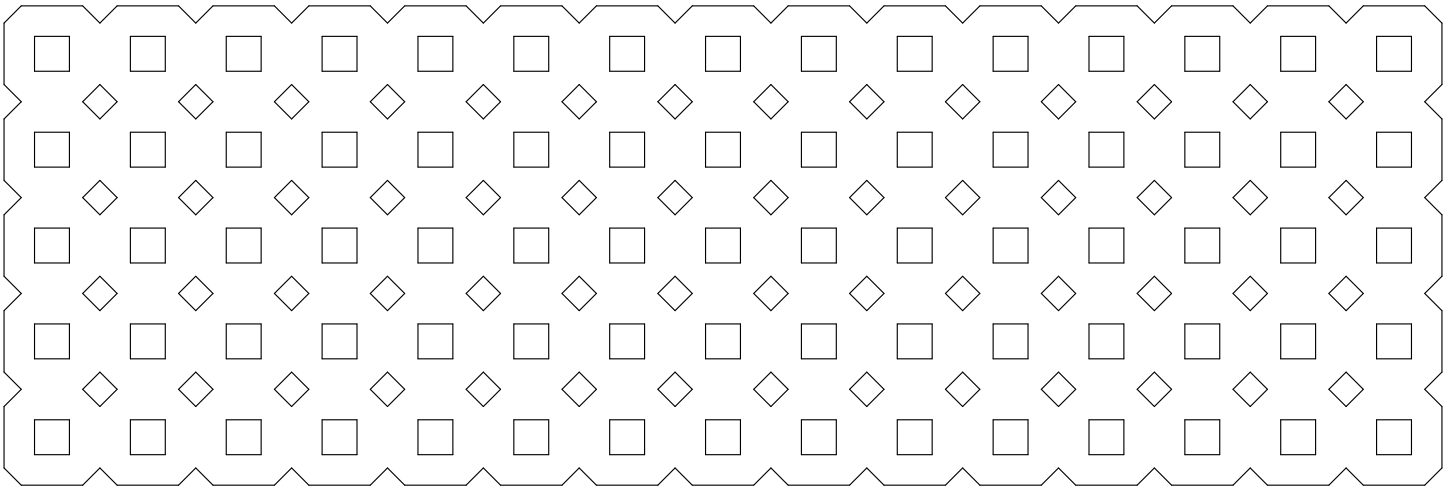

[P15] PLATE, 5 X 15 HOLE



[B1] 1" STANDOFF



[SQ3] 3" SHAFT



[NK]
8-32 KEPS NUT



[SS2]
1/4" MOTOR SCREW



[SP1]
SPACER THIN



[S2]
1/4" SCREW



[COL]
COLLAR

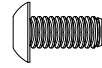

[S3]
3/8" SCREW



[BR]
POP RIVETS



[S4]
1/2" SCREW



[BF]
BEARING FLAT



[M29]
MOTOR CONTROLLER 29
(not shown to scale)



[MOT]
MOTOR
(not shown to scale)



[W5]
WHEELS, LARGE 5", KNOBBY
(not shown to scale)

OPTIONAL [NOT INCLUDED]



[BP]
7.2V RECHARGEABLE BATTERY
(optional accessory, not shown to scale)



[CTX]
CORTEX
(optional accessory, not shown to scale)



[VMC]
MICRO CONTROLLER
(optional accessory, not shown to scale)

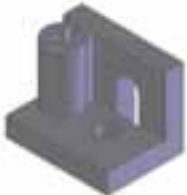

[AH]
ANTENNA HOLDER
(optional accessory, not shown to scale)



[BB]
7.2V AA BATTERY BOX
(optional accessory, not shown to scale)



[RX75]
RF RECEIVER & CABLE
(optional accessory, not shown to scale)



[BST]
BATTERY TIE DOWN
(optional accessory, not shown to scale)



[AT]
ANTENNA TUBE
(optional accessory, not shown to scale)



[5/64]x1



[3/32]x1



[WRENCH]X1

1

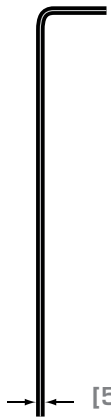

[5/64]



[SS2] 1/4" MOTOR SCREW

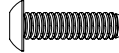

[SS4] 1/2" MOTOR SCREW
[OPTIONAL ACCESSORY]

2



[11/32"]



[NK] 8-32 KEPS NUT

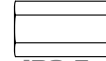

[BO.5, 1, 2, 3]

[1/4"]

3

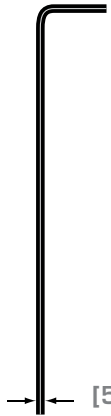

[5/64]

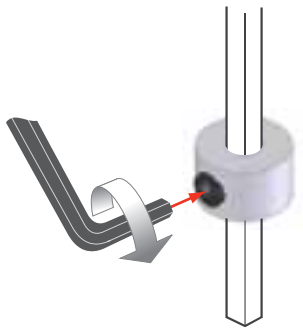

[COL] COLLAR

4

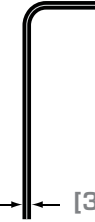

[3/32"]



[S2] 1/4" SCREW

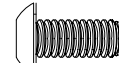

[S3] 3/8" SCREW

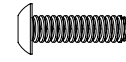

[S4] 1/2" SCREW

5

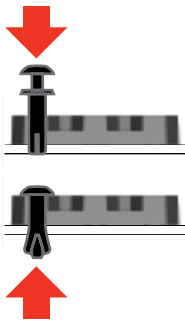

[BR] POP RIVETS



[BF] BEARING FLAT

6

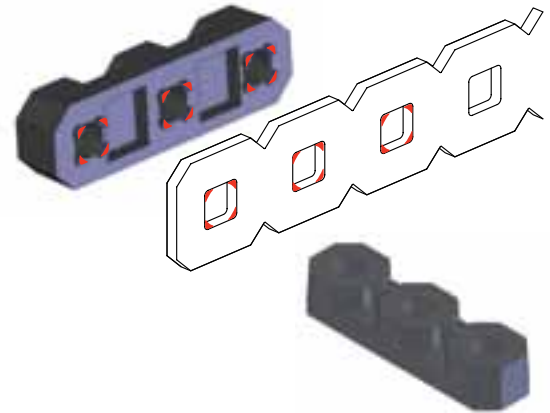

[BF] BEARING FLAT

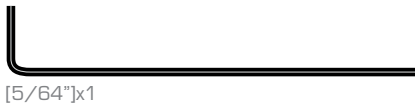

[5/64"]x1



[3/32"]x1



[WRENCH]x1

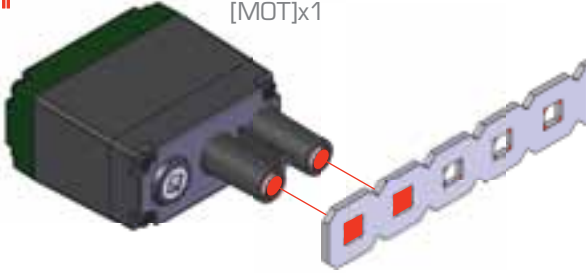

[MOT]x1



3-WIRE MOTOR

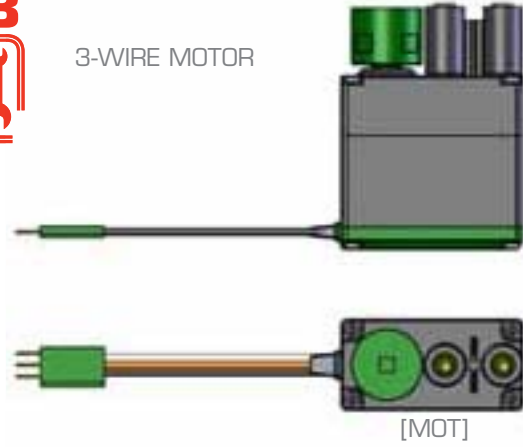

[MOT]



2-WIRE MOTOR WITH MOTOR CONTROLLER 29

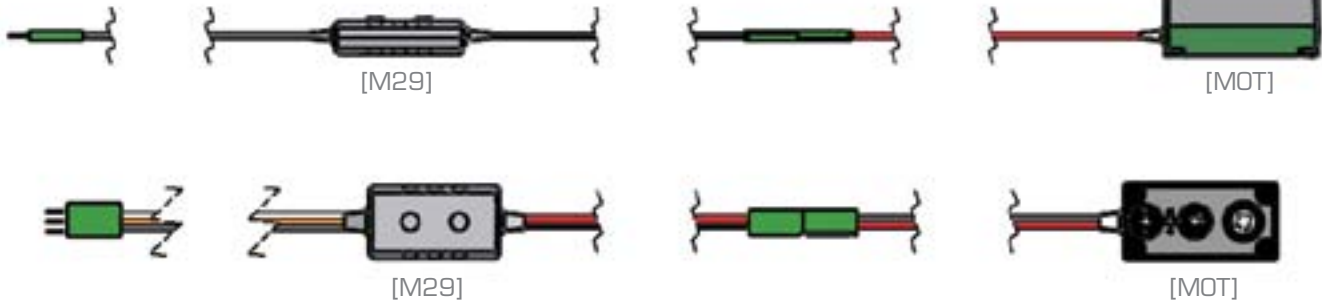

[M29]

[MOT]

[M29]

[MOT]

1

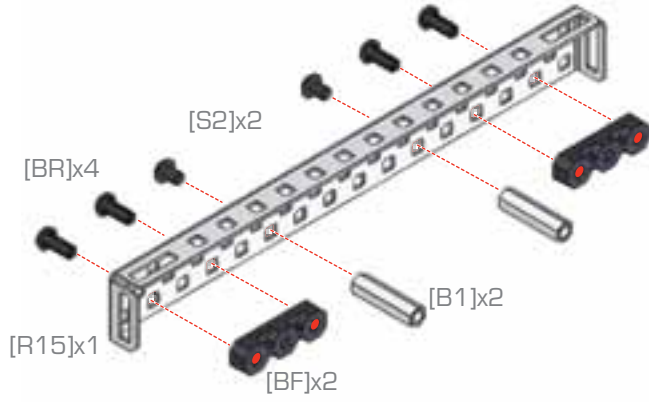

= 1

2

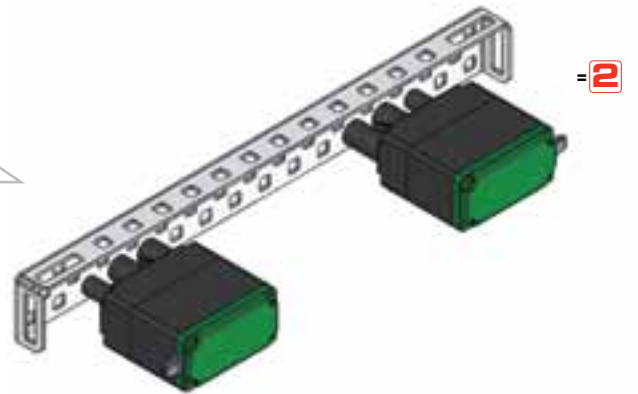
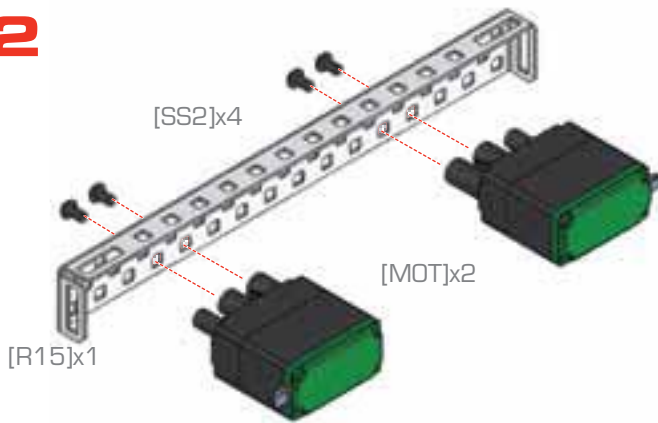

= 2

3

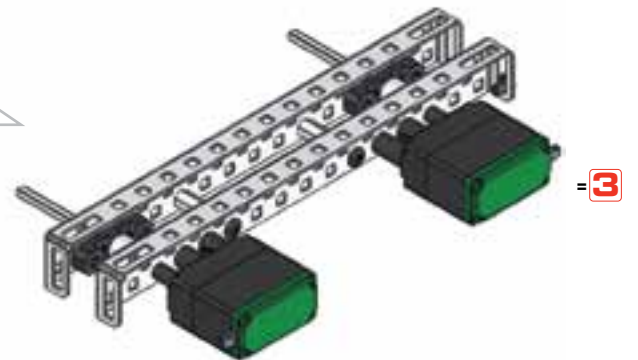
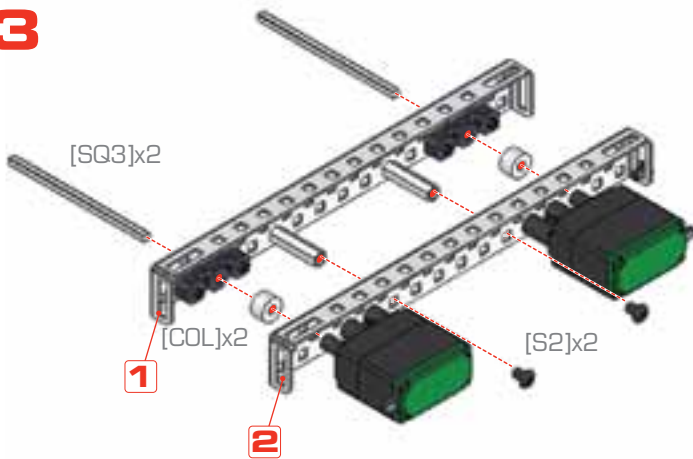

= 3

4

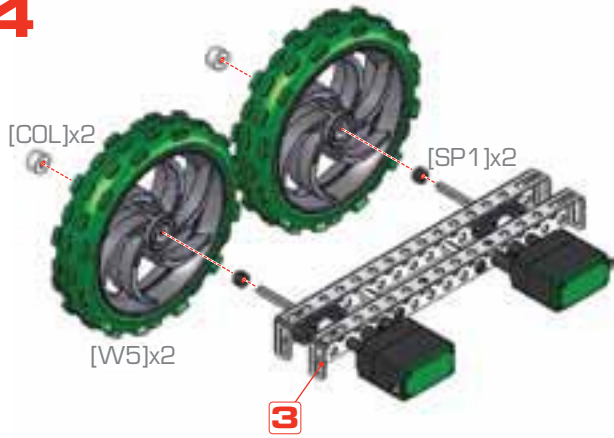

4

5

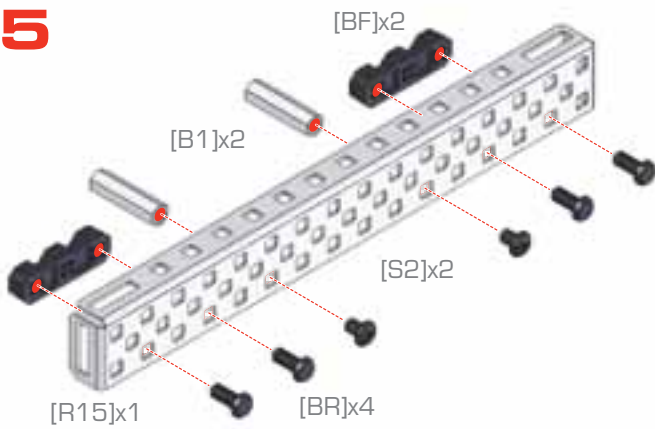

5

6

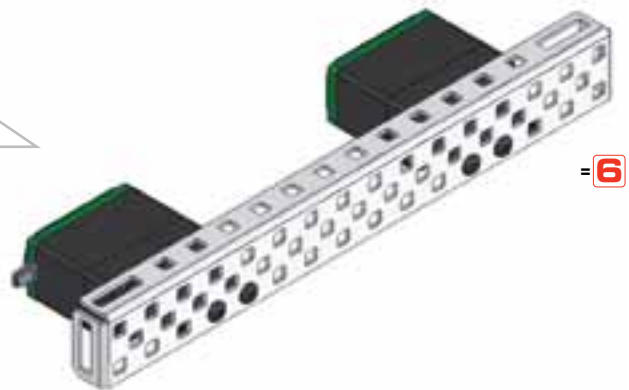
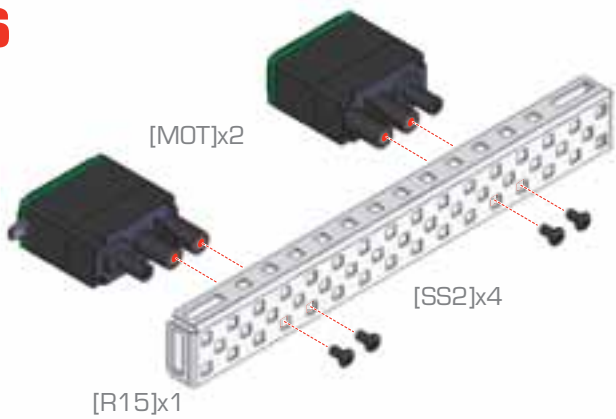

6

7

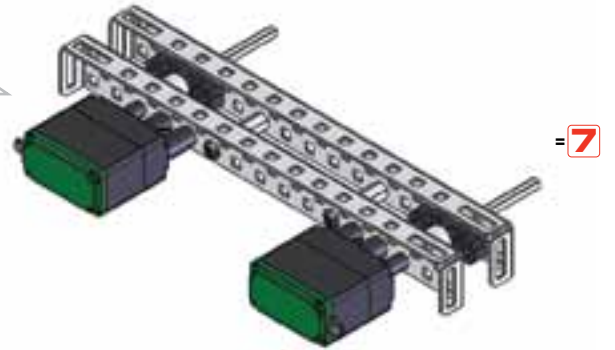
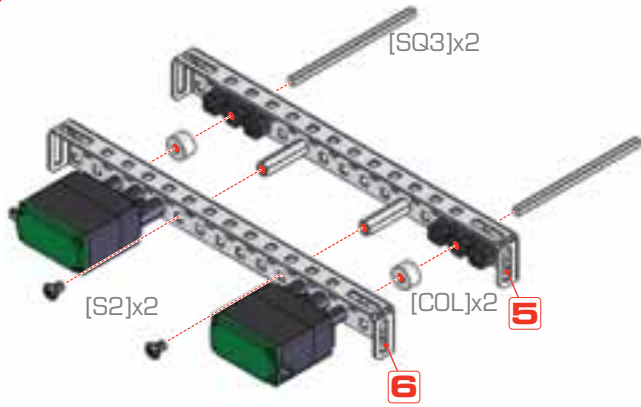

8



9

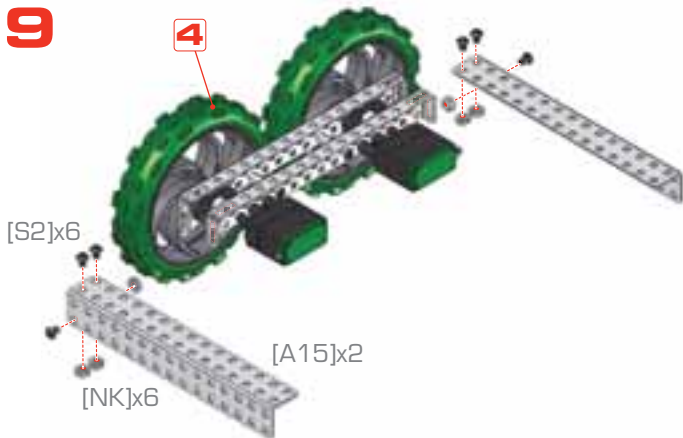

10

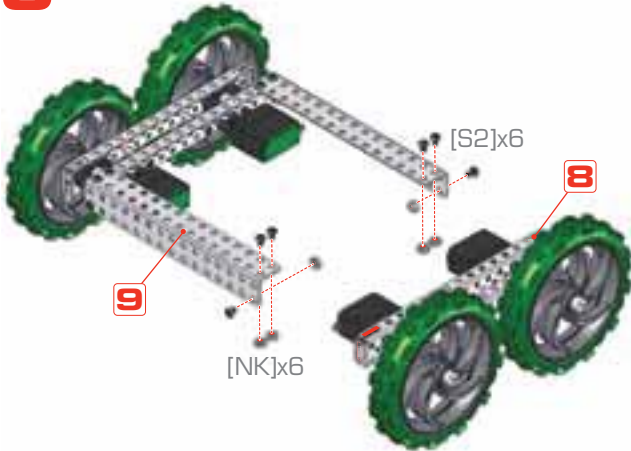

11

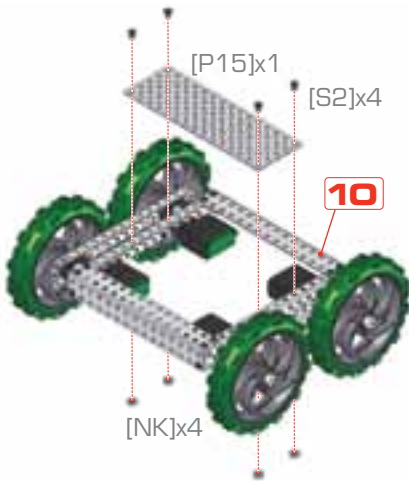

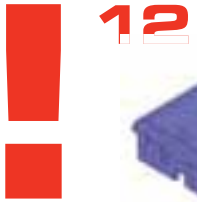

X1 [OPTIONAL]
OR SKIP TO 13

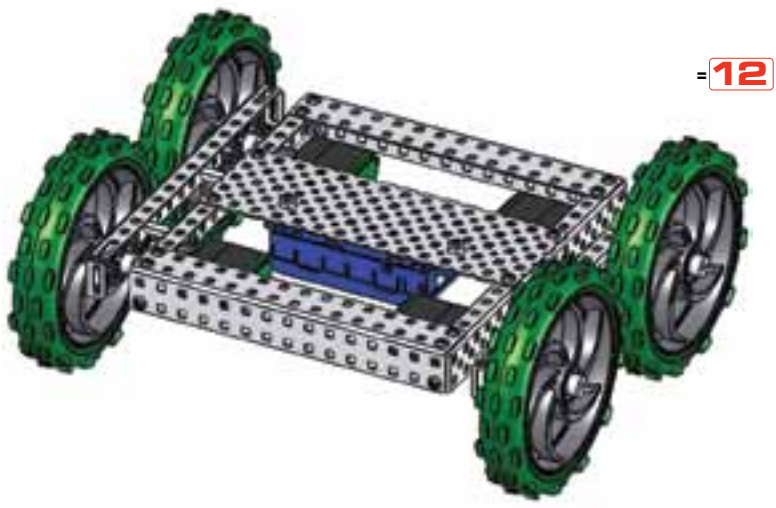
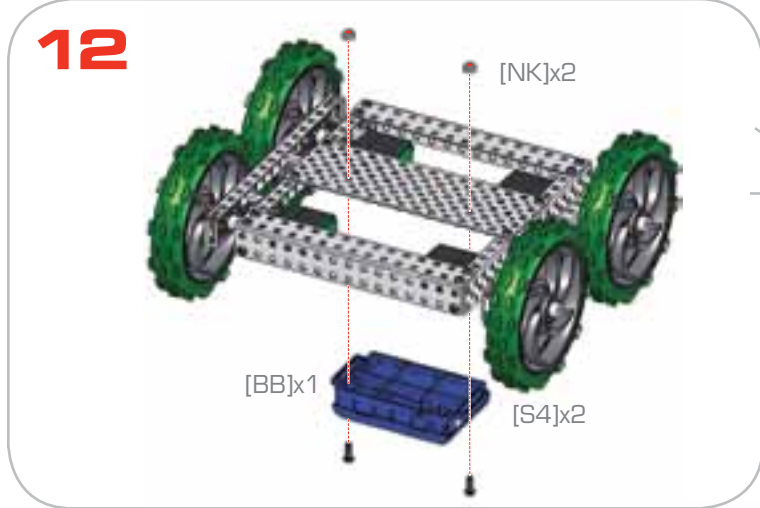

13-14



[OPTIONAL]
OR SKIP TO 15

13

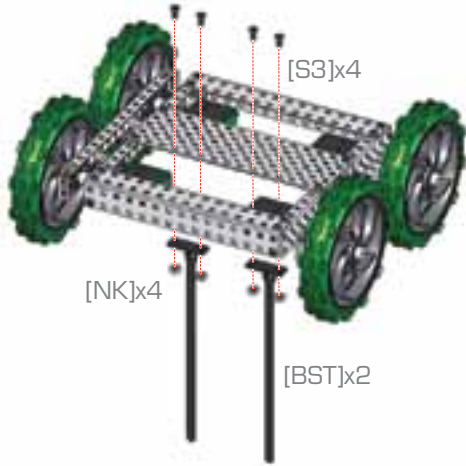

= 13



14

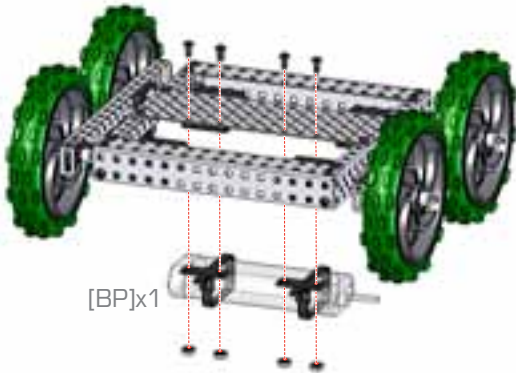

= 14



15



x1 [OPTIONAL]
OR SKIP TO 16

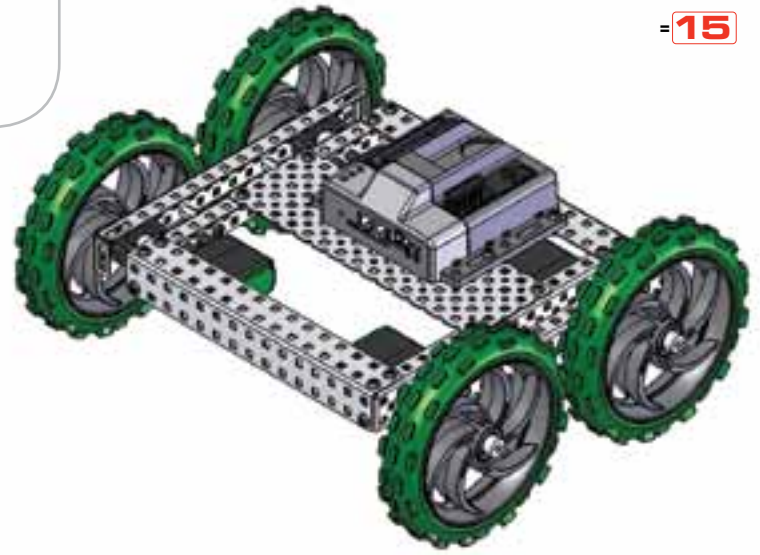
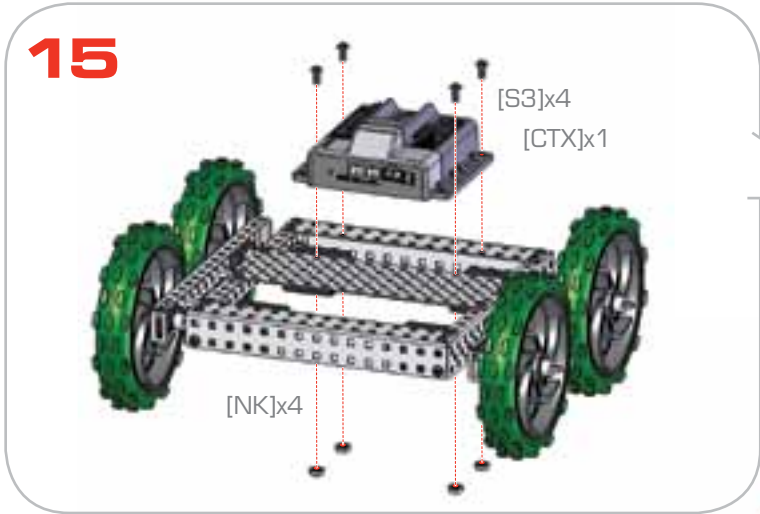

16-19



x1 [OPTIONAL]
OR SKIP TO 20

16

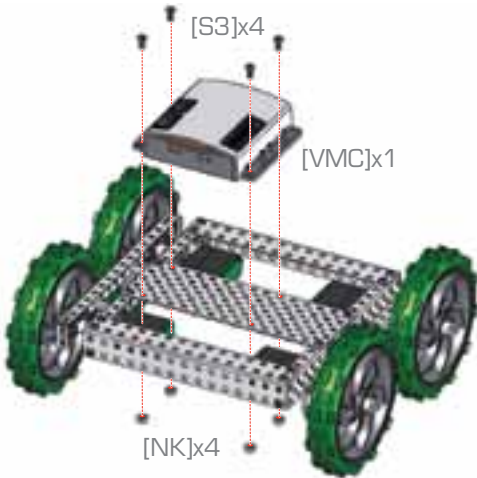

17

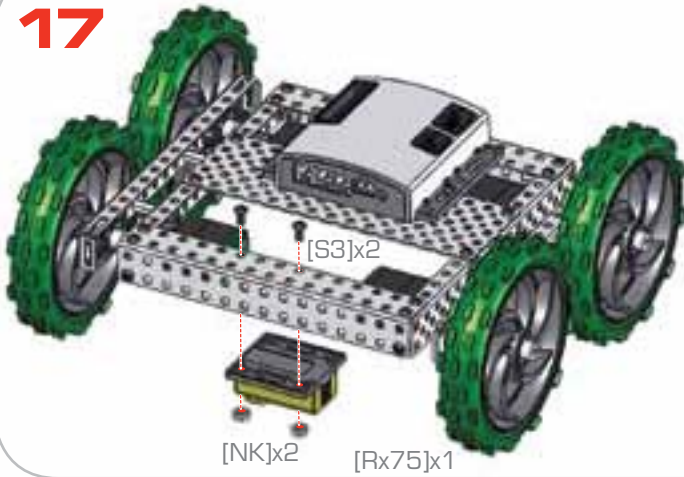

18

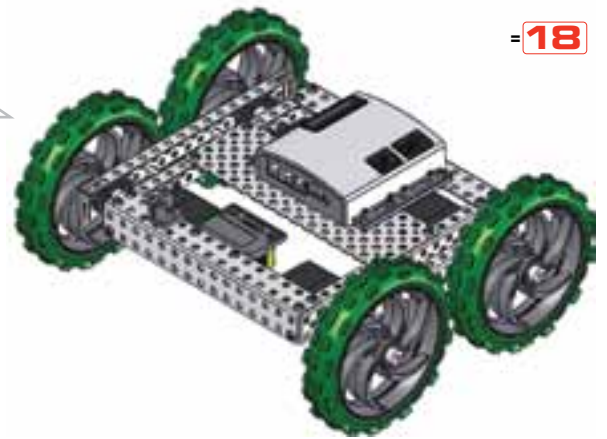
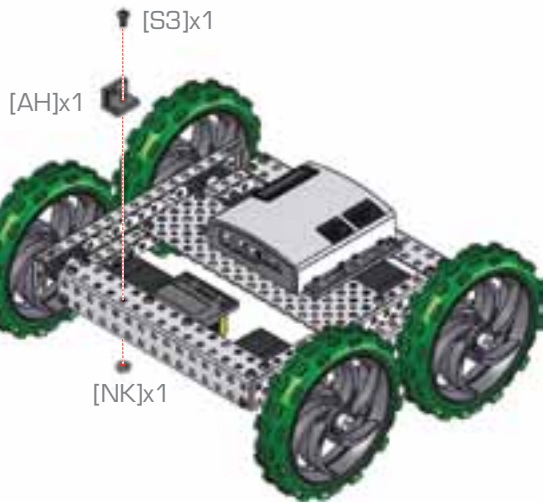

19

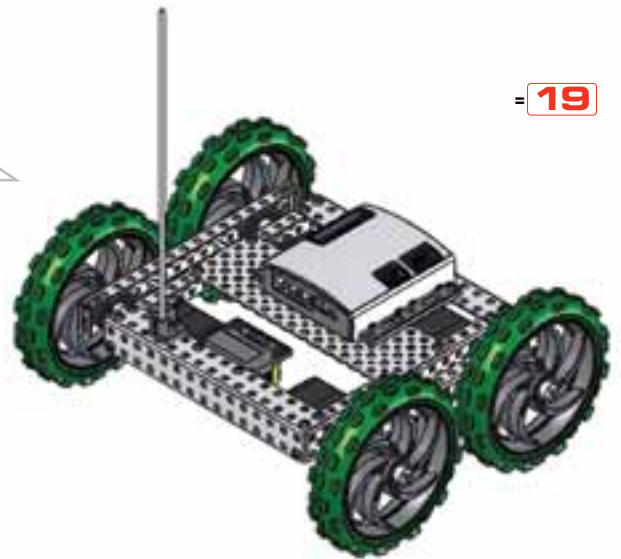
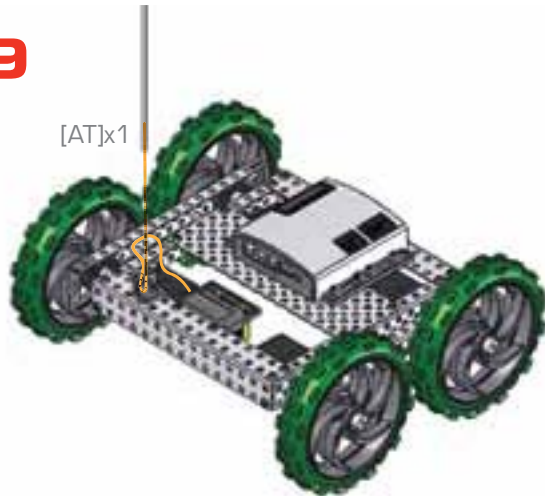

[CTX] WIRING [3 WIRE MOTORS]

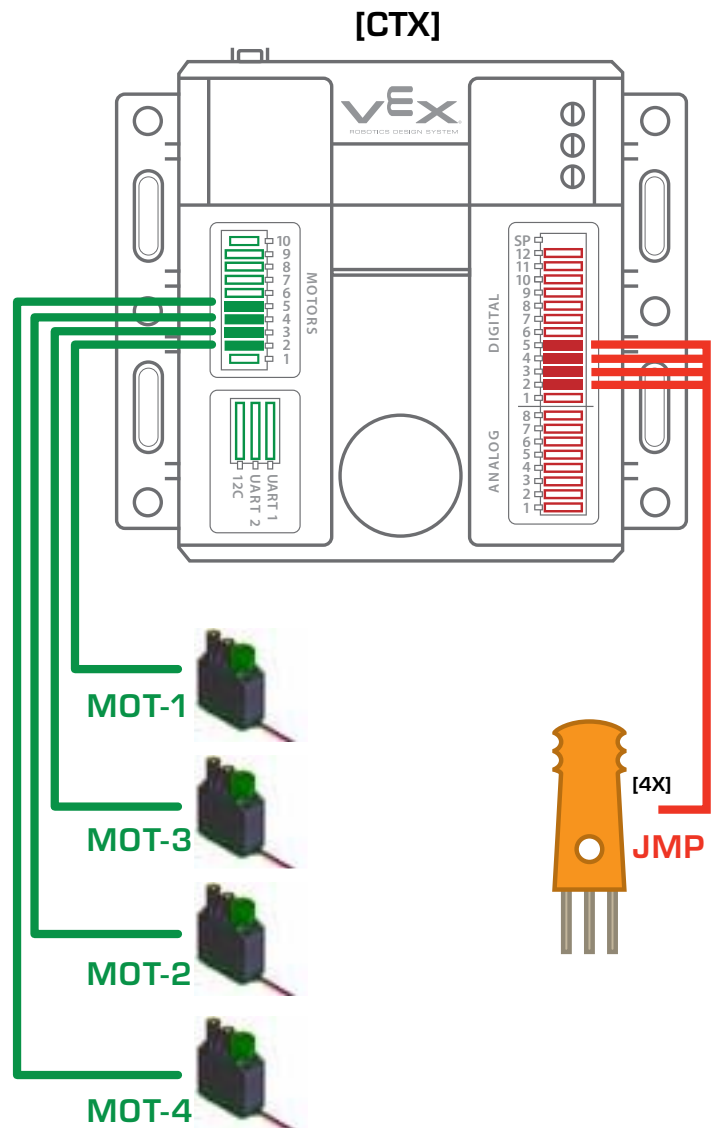
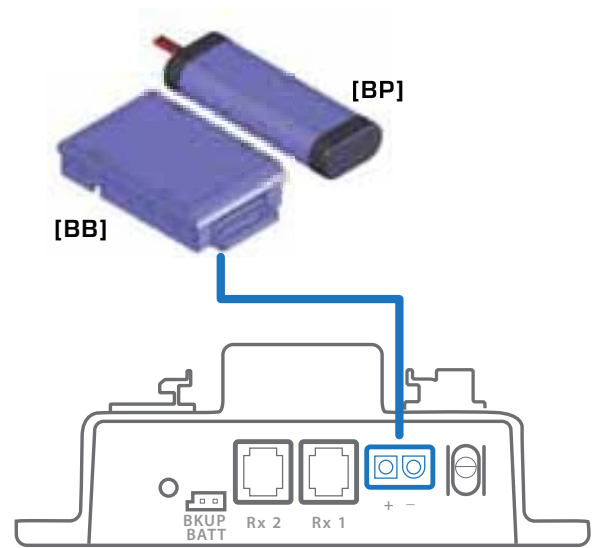
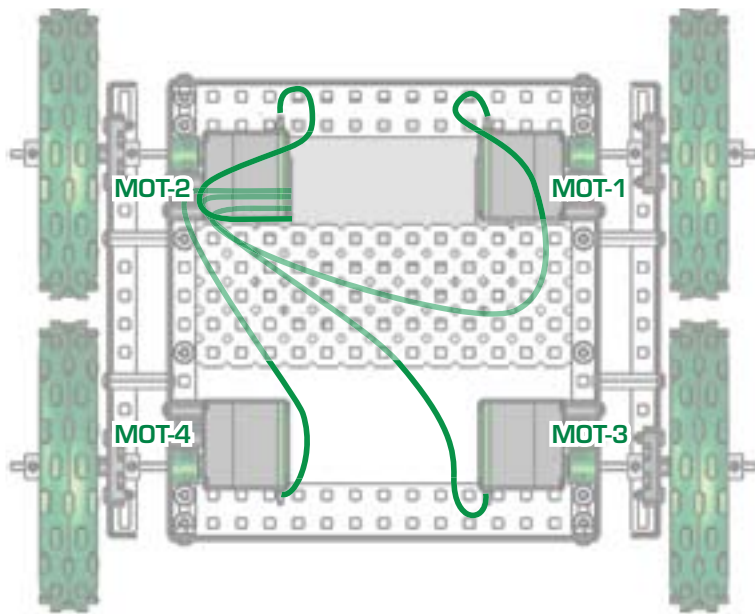
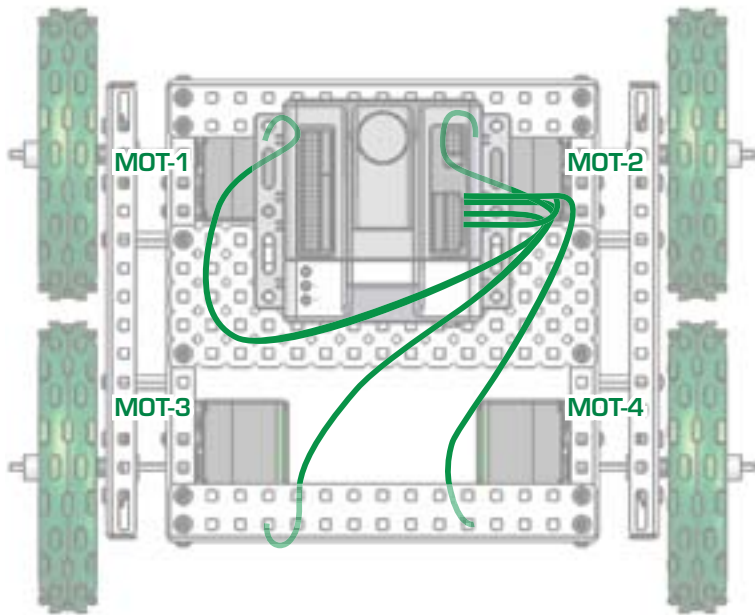

[CTX] WIRING [2 WIRE MOTORS]

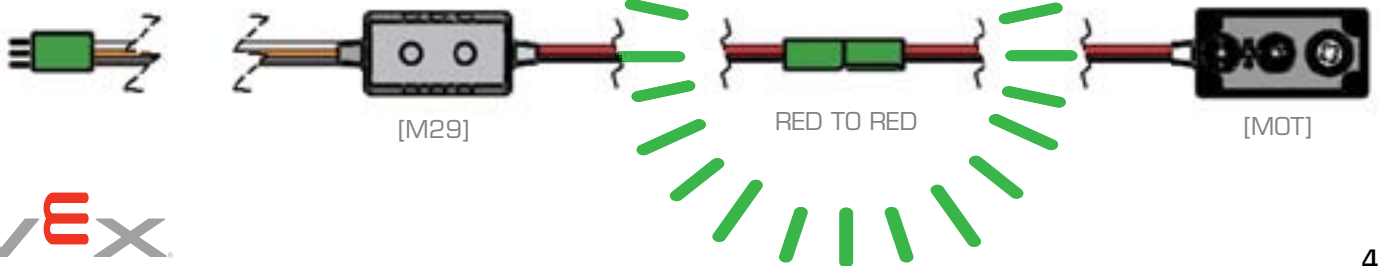
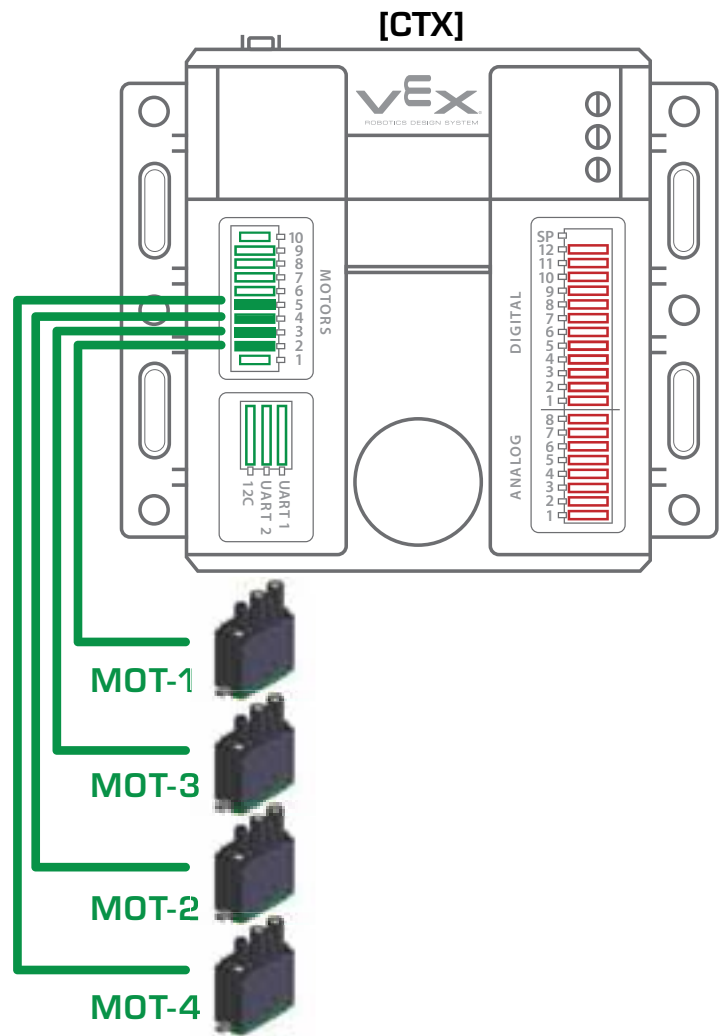
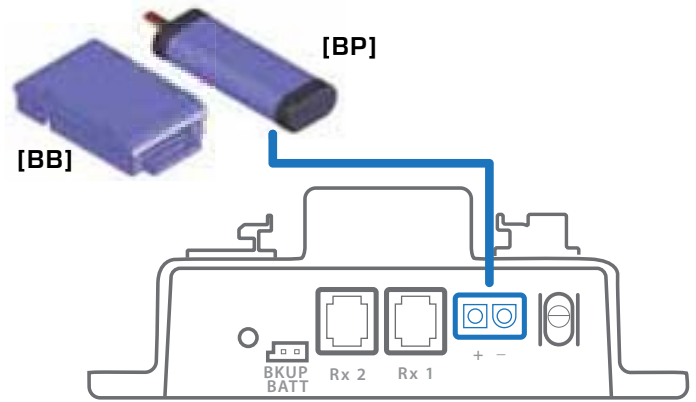
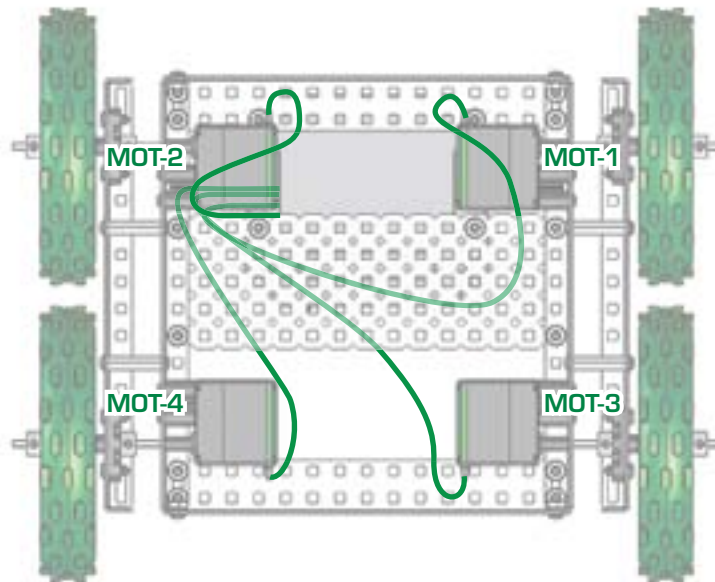
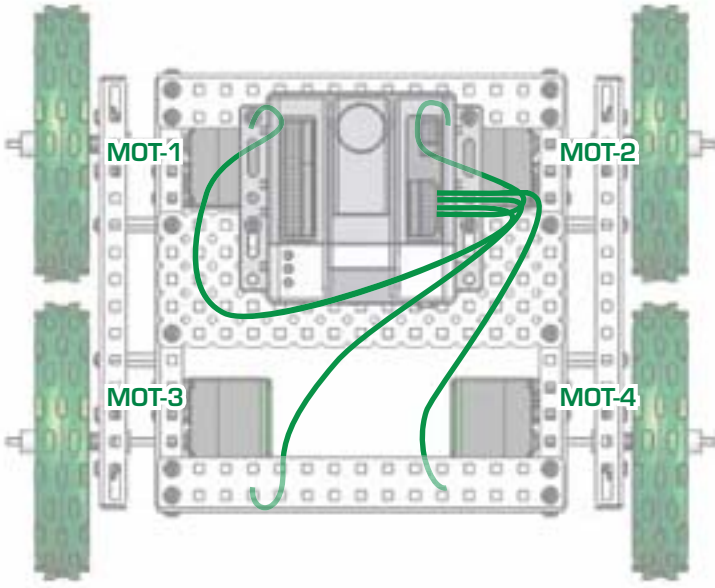

[VMC] WIRING

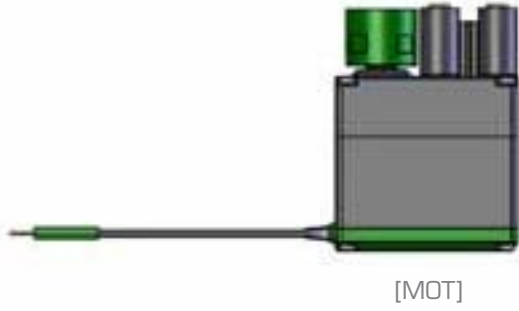

OR

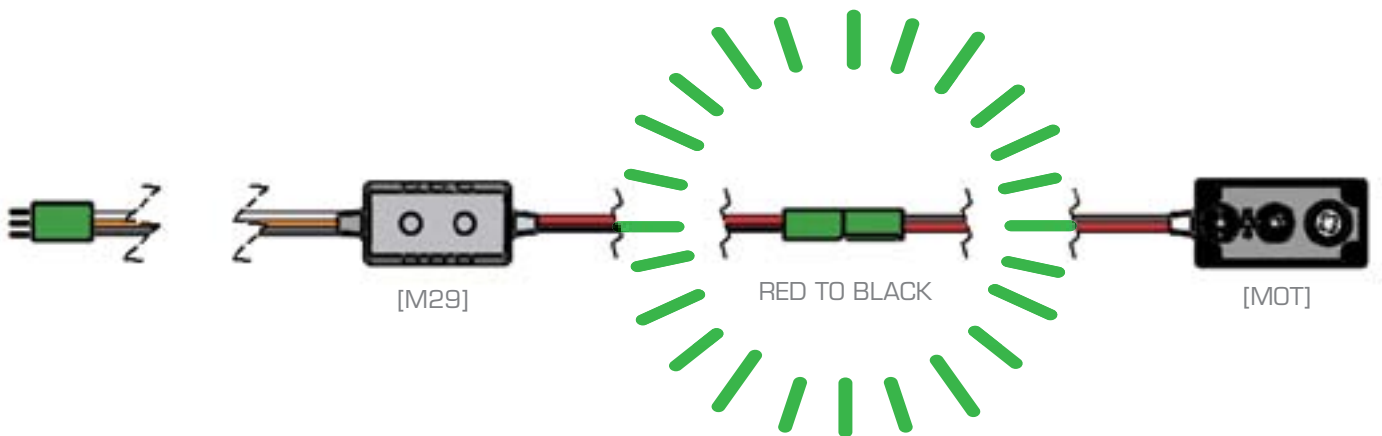
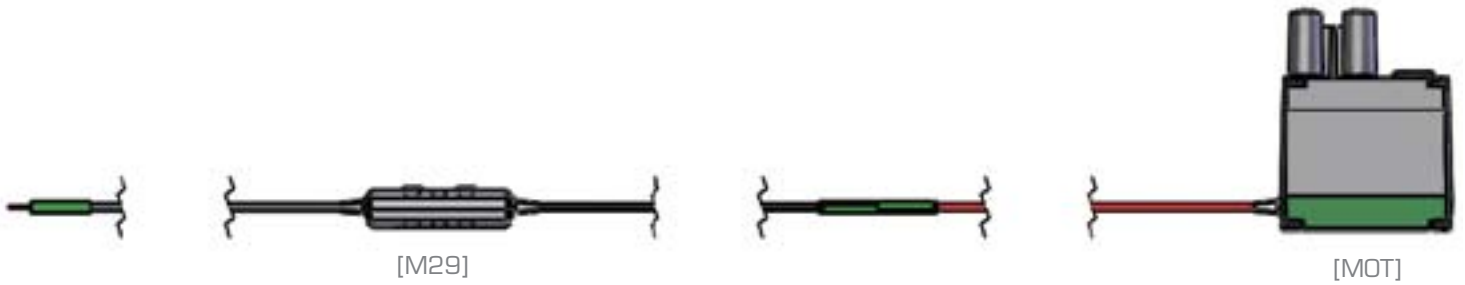

[VMC] WIRING

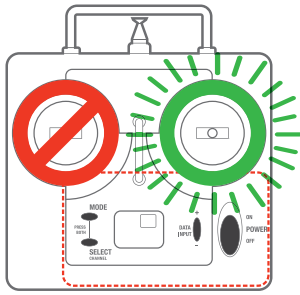

See Page 48

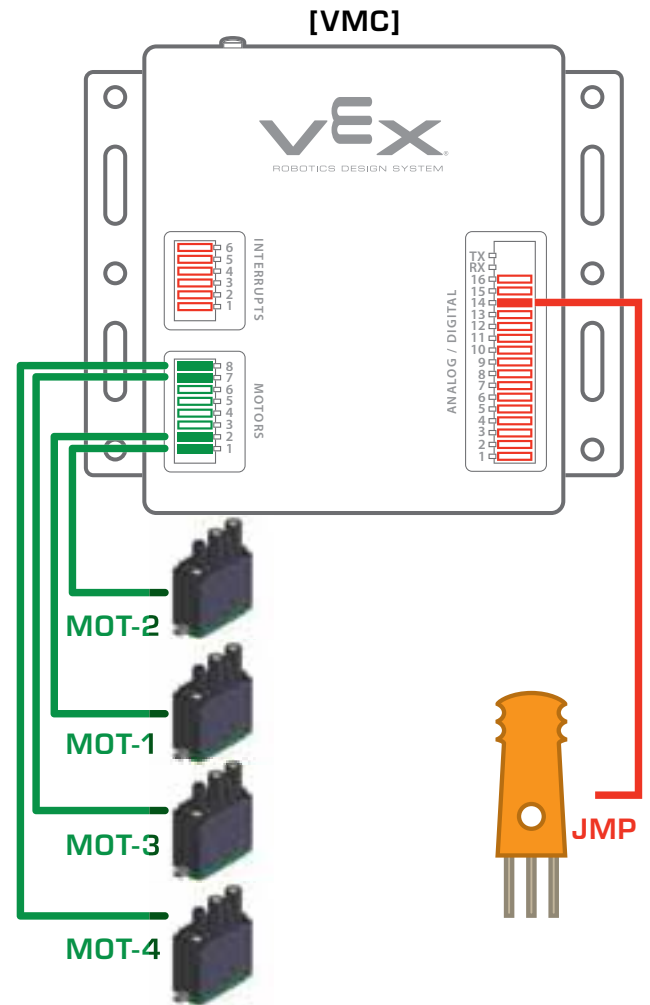
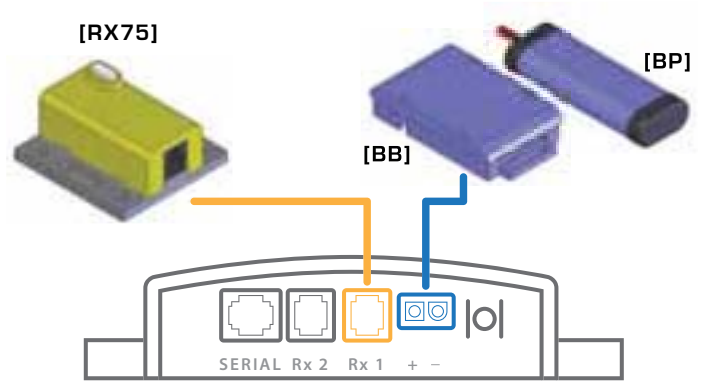
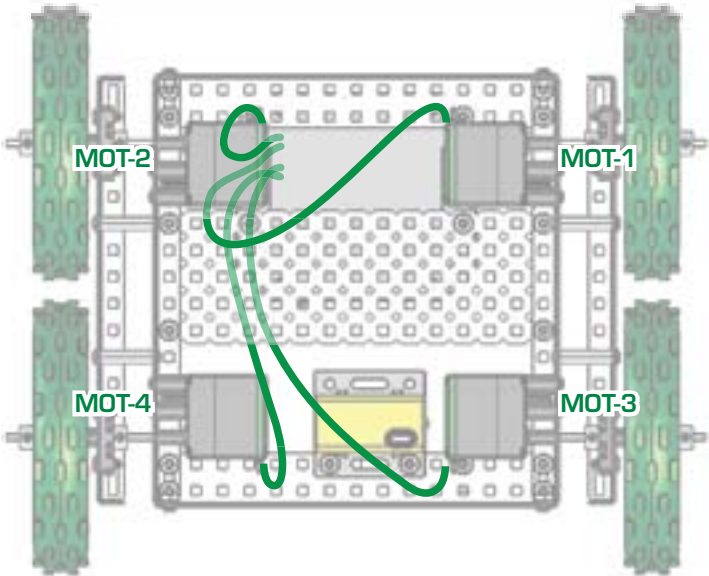
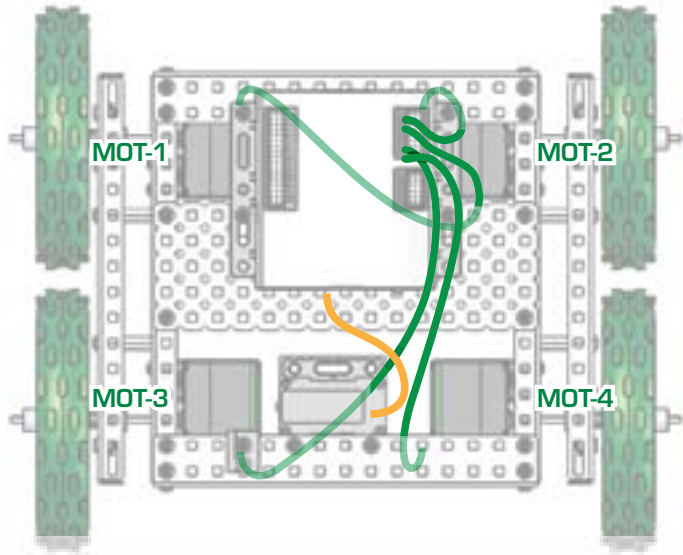

[VMC] WIRING

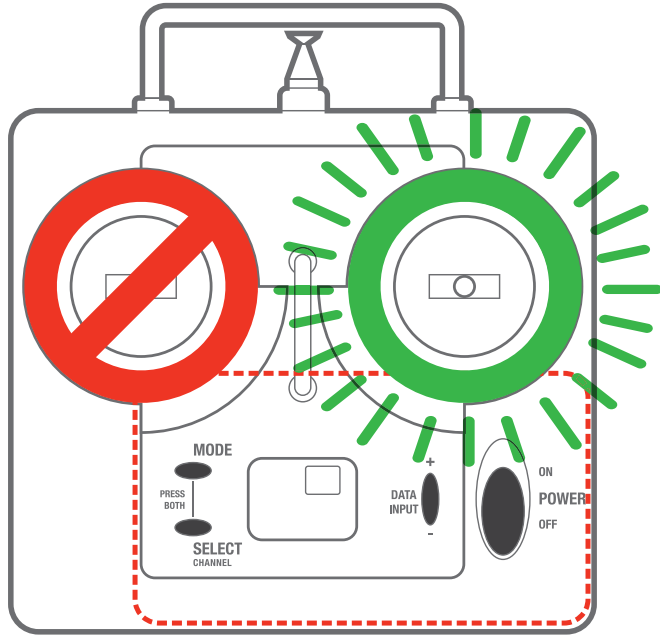

See Page 47

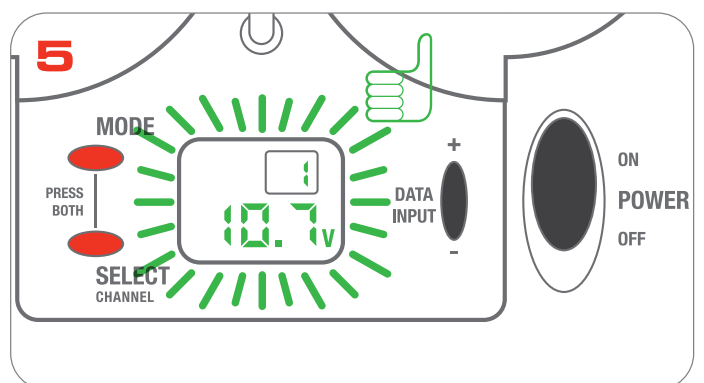
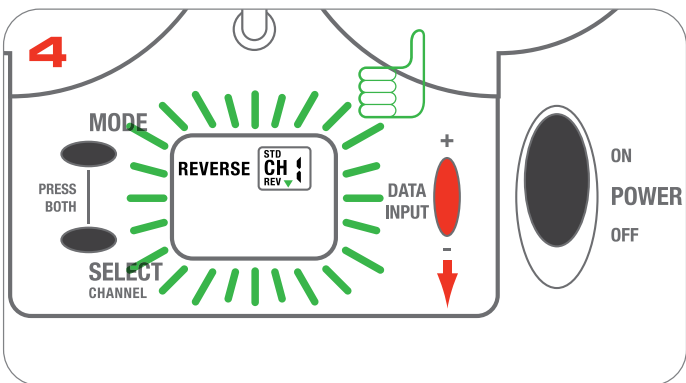
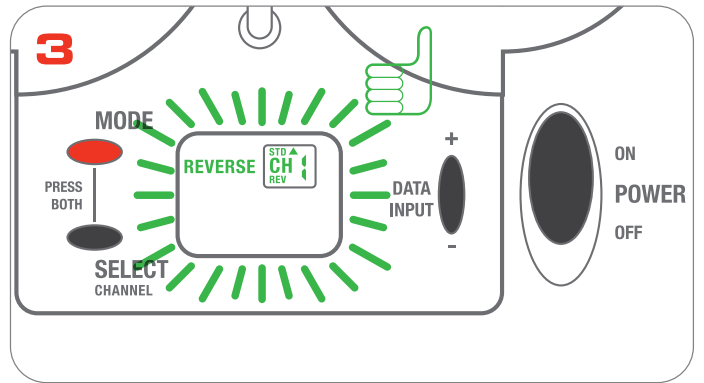
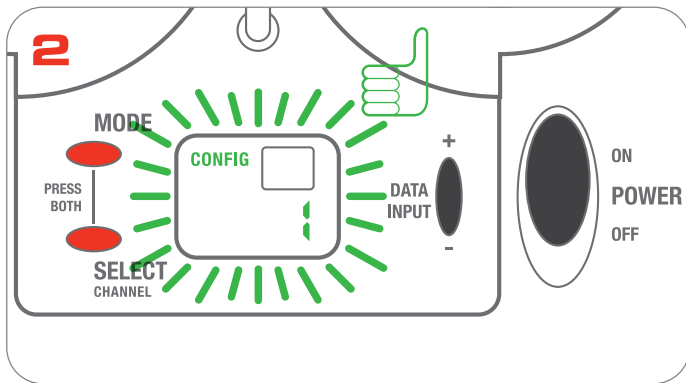
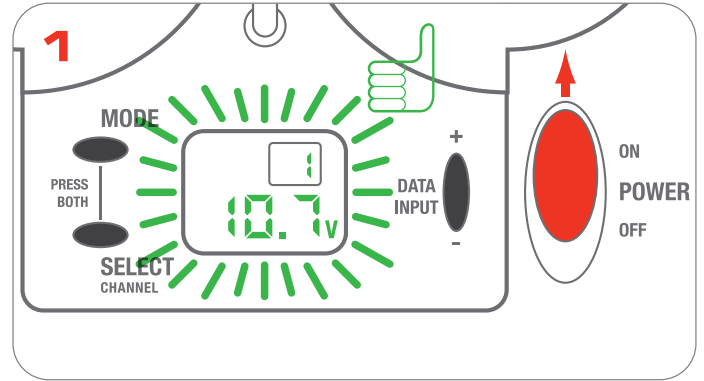

VEX ROBOTICS COMPETITION

The VEX Robotics Competition offers unique and challenging team-based games that put high school and middle school students' engineering and technology skills to the test. Students, with guidance from teachers and mentors, collaborate

to build the most innovative robots possible and work together during competitions to obtain the most points possible. In addition to having a great time and building amazing robots, through their participation in the VEX Robotics Competition and their work within their team, students learn many academic and life skills.



Local VEX Robotics competitions are held in many different cities, states and countries.

Visit RobotEvents.com to find the date and location of a VEX competition near you. Teams can register online to get an official team number, Team Welcome Kit and register for VEX Robotics Competition events.

Top teams from around the world participating in local, regional and national VEX Robotics Competitions will qualify for VEX Robotics international competitions and the VEX Robotics World Championship event held each Spring.



For more information about the VEX Robotics Competition and the VEX Robotics Design System, including various animations, videos, pictures and results from past VEX Robotics Competition events, visit VEXROBOTICS.com.

VEX
ROBOTICS
**WORLD
CHAMPIONSHIP**

A stylized world map graphic composed of a grid of dots, positioned behind the text.